

# GMH

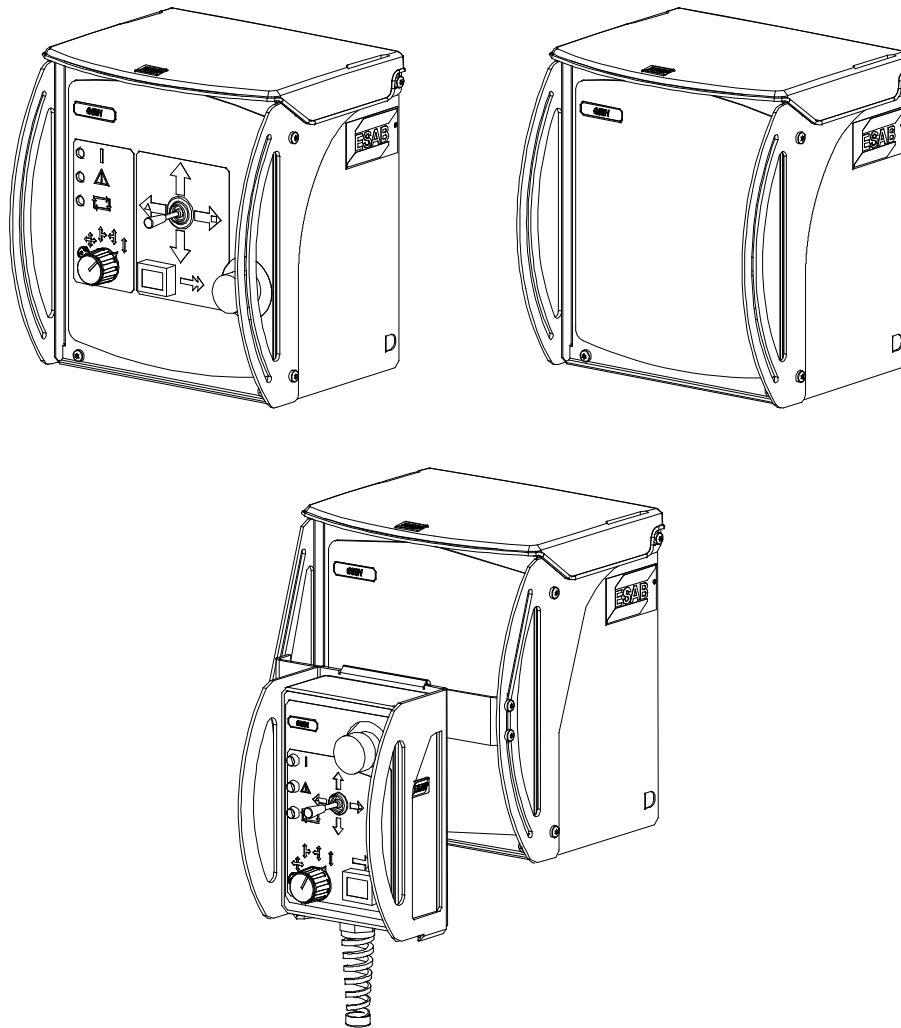

**Instruction manual**  
**Οδηγίες χρήσεως**  
**Instrukcja obsługi**  
**Kezelési utasítások**  
**Návod k používání**

**Navod na pouitie**  
**Lietošanas pamācība**  
**Eksploataavimo instrukcijos**  
**Priručnik s uputama**  
**Manualul de instrucțiuni**

ENGLISH .....	4
ΕΛΛΗΝΙΚΑ .....	24
POLSKI .....	44
MAGYAR .....	64
ČESKY .....	84
SLOVENSKY .....	104
LATVIEŠU .....	124
LIETUVIŪK .....	144
HRVATSKI .....	164
Rumanian .....	184

Rights reserved to alter specifications without notice.

Διατηρείται το δικαίωμα τροποποίησης προδιαγραφών Χωρίς προειδοποίηση.

Zastrzegamy sobie prawo do wprowadzenia zmian.

Fenntartjuk az előzetes bejelentés nélküli változtatás jogát.

Výrobce si vyhrazuje právo na změnu údajů bez předcházejícího upozornění.

Výrobca si vyhradzuje právo na uskutočnenie zmien bez upovedomenia.

Tiek paturjtas tiesibas bez iepriekšija brīdinājuma izmainīt specifikācijas.

Įmonė pasilieka teisę keisti specifikacijas be įspėjimo.

Rights reserved to alter specifications without notice.

Rights reserved to alter specifications without notice.



## DECLARATION OF CONFORMITY

according to the Low Voltage Directive 2006/95/EC, according to the EMC Directive 2004/108/EC

## FÖRSÄKRAN OM ÖVERENSSTÄMMELSE

enligt Lågspänningsdirektivet 2006/95/EG, enligt EMC-Direktivet 2004/108/EG

Type of equipment Materialslag  
Control box for joint-tracking

Brand name or trade mark Fabrikatnamn eller varumärke  
ESAB

Type designation etc. Typbeteckning etc.  
GMH, from serial number 936 xxx xxxx (2009 w.36)  
GMH is designed to be used with ESAB welding equipment

### Manufacturer or his authorised representative established within the EEA

Name, address, telephone No, telefax No: Tillverkarens namn, adress, telefon, telefax:

ESAB AB, Welding Equipment  
Esabvägen, SE-695 81 LAXÅ, Sweden  
Phone: +46 584 81 000, Fax: +46 584 411 924

The following harmonised standard in force within the EEA has been used in the design:  
Följande harmoniserande standarder har använts i konstruktionen:

EN 60974-1, Arc welding equipment – Part 1: Welding power sources, in relevant parts  
EN 60974-10, Arc welding equipment – Part 10: Electromagnetic compatibility (EMC) requirements

Additional information: / Tilläggsinformation: Restrictive use, this Control Box is use with equipment of Class A, intended for use in locations other than residential

**By signing this document, the undersigned declares as manufacturer, or the manufacturer's authorised representative established within the EEA, that the equipment in question complies with the safety requirements stated above.**

Genom att underteckna detta dokument försäkras undertecknad såsom tillverkare, eller tillverkarens representant inom EES, att angiven materiel uppfyller säkerhetskraven angivna ovan.

Date / Datum  
Laxå 2010-02-03

Signature / Underskrift

Kent Eimbrodt  
Clarification

Position / Befattning  
Global Director  
Equipment and Automation

<b>1 SAFETY</b> .....	<b>5</b>
<b>2 INTRODUCTION</b> .....	<b>7</b>
2.1 General .....	7
2.2 Variants .....	7
2.3 Technical data .....	8
2.4 Main parts .....	9
<b>3 INSTALLATION</b> .....	<b>11</b>
3.1 General .....	11
3.2 Installation and connection .....	11
3.3 Tuning the sensor finger .....	11
3.4 Tuning the inductive sensor .....	11
<b>4 OPERATION</b> .....	<b>12</b>
4.1 General .....	12
4.2 Joint-tracking unit with control panel .....	12
4.3 Joint-tracking unit – rear section .....	14
4.4 Portable control box .....	15
4.5 Joint-tracking .....	17
4.6 Positioning for welding start .....	20
4.7 Positioning for welding start (with inductive joint-tracking) .....	21
<b>5 MAINTENANCE</b> .....	<b>22</b>
5.1 General .....	22
5.2 Wear parts .....	22
<b>6 ORDERING OF SPARE PARTS</b> .....	<b>22</b>
<b>7 ACCESSORIES</b> .....	<b>23</b>
<b>DIAGRAM</b> .....	<b>204</b>
<b>DIMENSION DRAWING</b> .....	<b>207</b>
<b>SPARE PARTS LIST</b> .....	<b>211</b>

---

# 1 SAFETY

---

**NOTE!** *The unit is tested by ESAB in a general purpose operation. Responsibility for the safety and function of the final operation lies with the Integrator.*

Users of ESAB welding equipment have the ultimate responsibility for ensuring that anyone who works on or near the equipment observes all the relevant safety precautions. Safety precautions must meet the requirements that apply to this type of welding equipment. The following recommendations should be observed in addition to the standard regulations that apply to the workplace.

All work must be carried out by trained personnel well-acquainted with the operation of the welding equipment. Incorrect operation of the equipment may lead to hazardous situations which can result in injury to the operator and damage to the equipment.

1. Anyone who uses the welding equipment must be familiar with:
  - its operation
  - location of emergency stops
  - its function
  - relevant safety precautions
  - welding
2. The operator must ensure that:
  - no unauthorised person is stationed within the working area of the equipment when it is started up.
  - no-one is unprotected when the arc is struck
3. The workplace must:
  - be suitable for the purpose
  - be free from draughts
4. Personal safety equipment
  - Always wear recommended personal safety equipment, such as safety glasses, flame-proof clothing, safety gloves.
  - Do not wear loose-fitting items, such as scarves, bracelets, rings, etc., which could become trapped or cause burns.
5. General precautions
  - Make sure the return cable is connected securely.
  - Work on high voltage equipment **may only be carried out by a qualified electrician.**
  - Appropriate fire extinguishing equipment must be clearly marked and close at hand.
  - Lubrication and maintenance must **not** be carried out on the equipment during operation.



# WARNING



**ARC WELDING AND CUTTING CAN BE INJURIOUS TO YOURSELF AND OTHERS. TAKE PRECAUTIONS WHEN WELDING. ASK FOR YOUR EMPLOYER'S SAFETY PRACTICES WHICH SHOULD BE BASED ON MANUFACTURERS' HAZARD DATA.**

**ELECTRIC SHOCK - Can kill**

- Install and earth the welding unit in accordance with applicable standards.
- Do not touch live electrical parts or electrodes with bare skin, wet gloves or wet clothing.
- Insulate yourself from earth and the workpiece.
- Ensure your working stance is safe.

**FUMES AND GASES - Can be dangerous to health**

- Keep your head out of the fumes.
- Use ventilation, extraction at the arc, or both, to take fumes and gases away from your breathing zone and the general area.

**ARC RAYS - Can injure eyes and burn skin.**

- Protect your eyes and body. Use the correct welding screen and filter lens and wear protective clothing.
- Protect bystanders with suitable screens or curtains.

**FIRE HAZARD**

- Sparks (spatter) can cause fire. Make sure therefore that there are no inflammable materials nearby.

**NOISE - Excessive noise can damage hearing**

- Protect your ears. Use earmuffs or other hearing protection.
- Warn bystanders of the risk.

**MALFUNCTION - Call for expert assistance in the event of malfunction.**

**READ AND UNDERSTAND THE INSTRUCTION MANUAL BEFORE INSTALLING OR OPERATING.**

**PROTECT YOURSELF AND OTHERS!**

## 2 INTRODUCTION

### 2.1 General

**GMH** is joint-tracking equipment for the positioning and joint-tracking of automatic welding equipment in all types of joint that arise where the sensor finger has a guiding edge to follow. The equipment is adapted to ESAB's standard servo slides and control one or two servo motors simultaneously.

The system is available in several variants, see below.

### 2.2 Variants

- Joint-tracking unit with control panel.

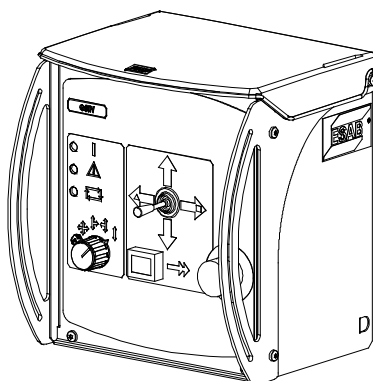

- Joint-tracking unit with portable control box.

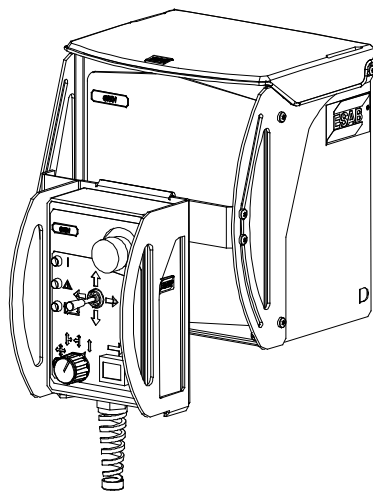

- Built-in component for columns and booms.

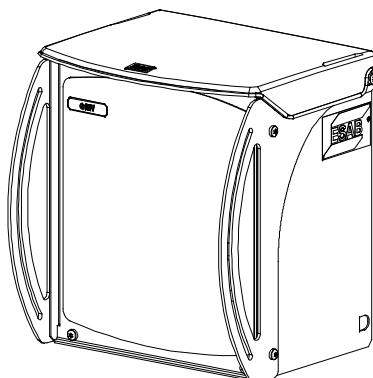

## 2.3 Technical data

	<b>GMH</b>
<b>Supply voltage</b>	42V AC, 50-60 Hz
<b>Current output</b>	450 V A
<b>Ambient temperature</b>	-15° C - + 45° C
<b>Relative atmospheric humidity</b>	Max. 98%
<b>Max. motor current</b>	6A 100%
<b>Enclosure class</b>	IP 23
<b>Current limits</b>	15 A (hardware current limit)
<b>Power supply fusing</b>	10 A slow
<b>Motor regulator, type</b>	Switched four quadrant reg.
<b>Rotor voltage</b>	40 V DC
<b>Field voltage, separate magnetised motor</b>	60 V DC
<b>Weights:</b>	
Joint-tracking unit:	6,2 kg
Portable control box:	2,7 kg (complete with 4m cable and protection)
Sensor and slide cross with bracket:	2.2 kg
Guide finger:	0.6 kg
<b>Working range sensor, radially 360°</b>	4 mm

### Enclosure class

The **IP** code indicates the enclosure class, i. e. the degree of protection against penetration by solid objects or water. Equipment marked **IP 23** is designed for indoor and outdoor use.

Working range and setting speed, see the figure below and the technical description in the operating instructions for A6 Slide.

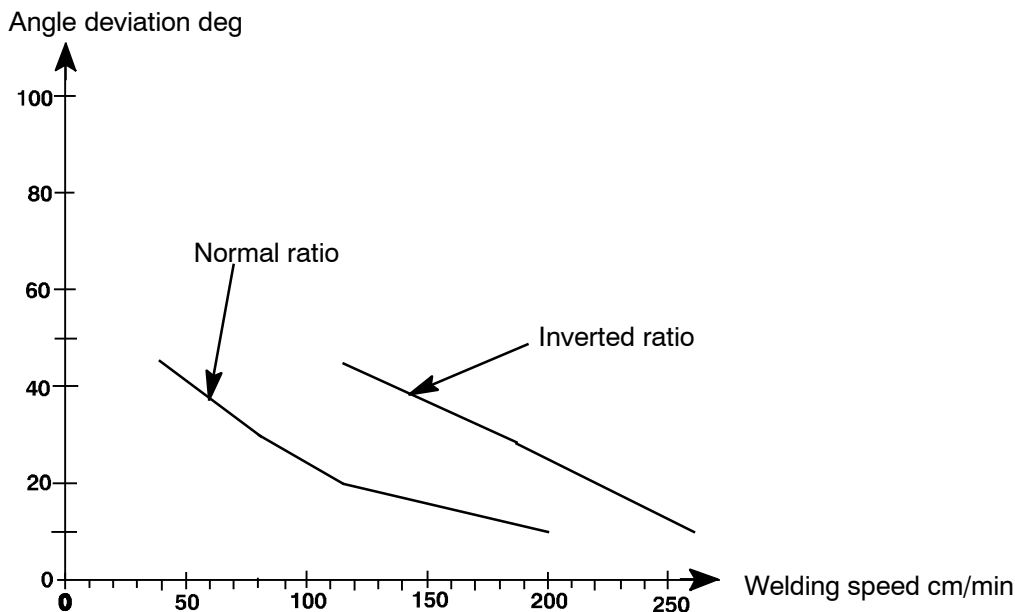

*Diagram of the weld joint's maximum angle deviation in relation to the set welding speed.*



## 2.4 Main parts

1. Joint-tracking unit (with or without control panel)
2. Portable control box
3. Sensor
4. Slide cross for sensor
5. Guide finger
6. Control cable (2 m)
7. Motor cable (see **Accessories**)

**NB!**

The *portable control box (2)* and the *control cable (6)*, in accordance with the above, are discontinued for certain columns and booms and are replaced by product specific parts.

For more information, see the chapter "**Operation**", on page 12.

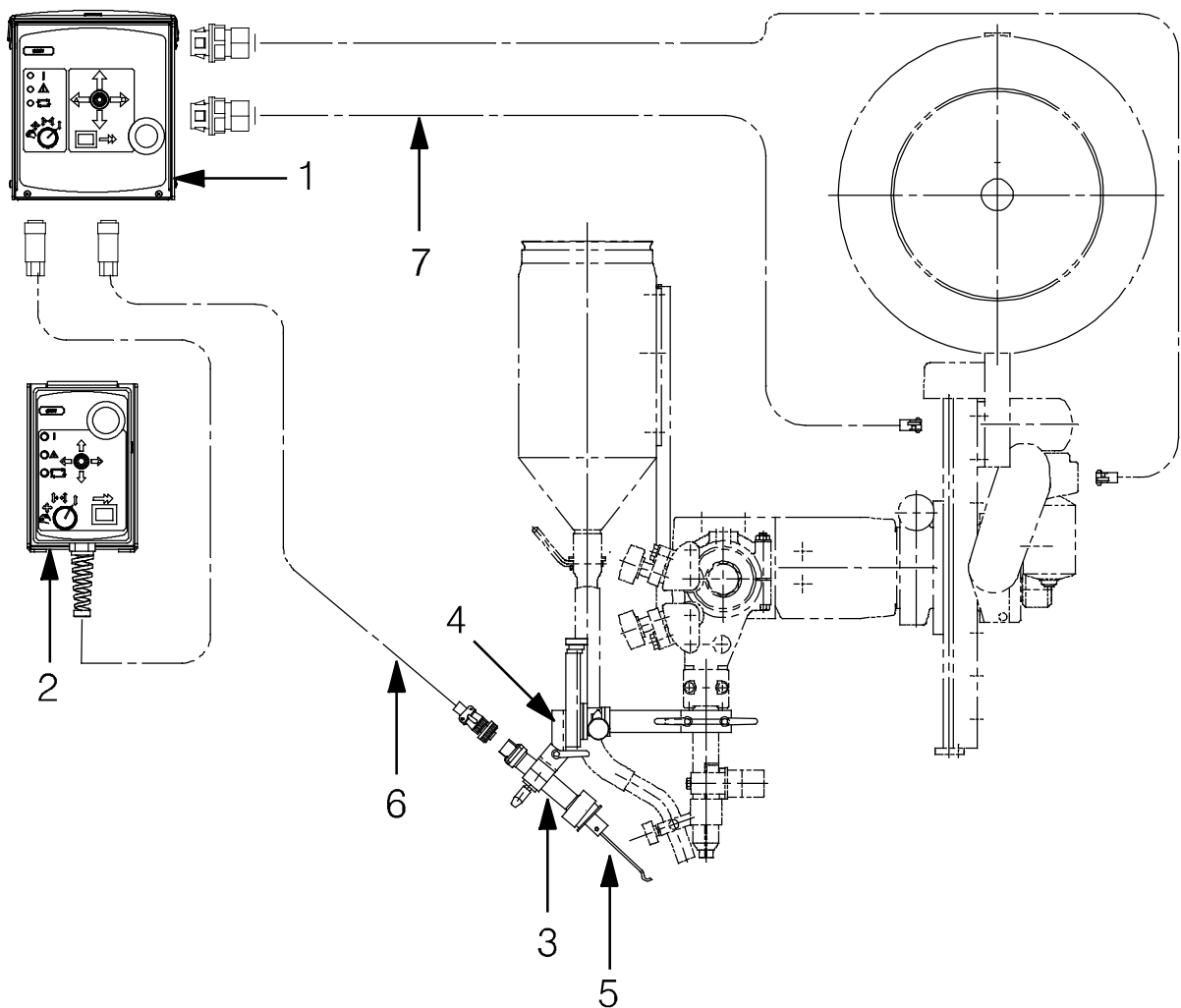

### 2.4.1 Sensor

The sensor is shaped like a finger. The finger is spring-loaded so that it attempts to reach the centre position laterally and downwards vertically.

1. Sensor with connection for cable to joint-tracking unit and with bracket for different tracking fingers at the front.
2. Joint-tracking fingers
3. Stop screws (two) for adjusting finger movement horizontally. The screws enable settings for different joint types.

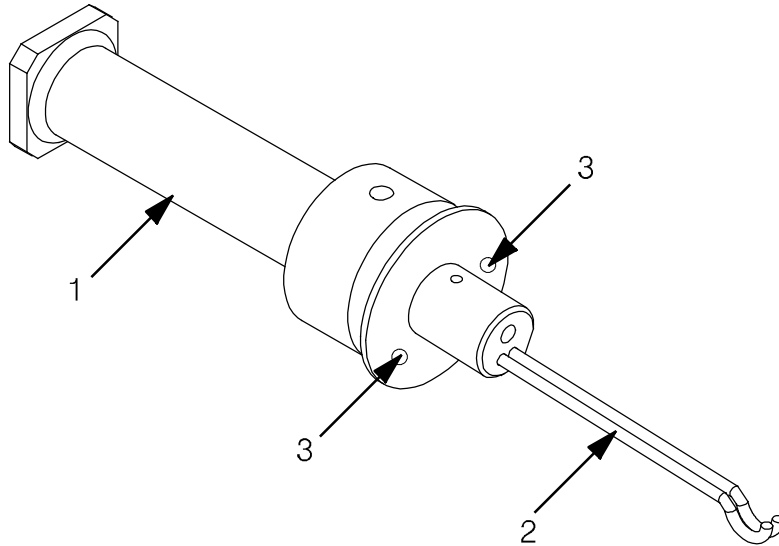

---

## **3    INSTALLATION**

---

### **3.1    General**

*The installation must be executed by a professional.*

### **3.2    Installation and connection**

1. Measurement information, see the dimension drawings on pages 207–209.
2. Connection, see the diagrams on pages 204–206
3. Check that the required output and voltage is available for complete installation.
4. Fit the guide finger parallel with the motor driven slide cross.

### **3.3    Tuning the sensor finger**

Please refer to ESAB's service department for tuning the sensor finger.

### **3.4    Tuning the inductive sensor**

Please refer to ESAB's service department for tuning the inductive sensor.

## 4 OPERATION

### 4.1 General

**General safety regulations for the handling of the equipment can be found on page 5. Read through before you start using the equipment!**

### 4.2 Joint-tracking unit with control panel

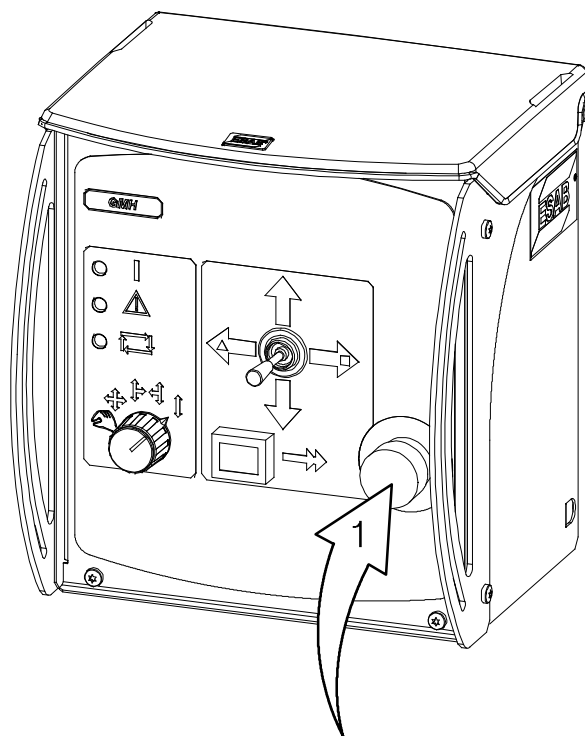

#### **Emergency stop (1)**

- One press on the button activates EMERGENCY STOP

**NB!** An emergency stop must never be reset before the cause of the abnormal function or signal has been established and rectified.

**Signal lamp** ○ □ (white)

- Illuminates when the power has been switched on.

**Alarm lamp (automatic joint-tracking)** ○ ▲ (yellow)

- Illuminates when the guide finger is outside the working range (vertical). The automatic function is then blocked.



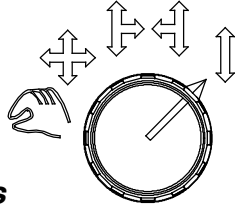

**Signal lamp (joint-tracking)** ○ ◻ (green)

- Illuminates when automatic joint-tracking is in progress.



**Switch with 5 positions**

Selection of joint-tracking and joint-searching options:

- Manual preset - Position 
- Vertical and horizontal joint-tracking - Position 
- Vertical and horizontal joint-tracking with joint-searching to the right - Position 
- Vertical and horizontal joint-tracking with joint-searching to the left - Position 
- Vertical joint-tracking - Position 

**NOTE!**

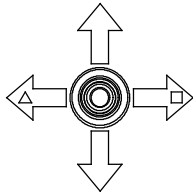

If the switch is in a joint-tracking position when the equipment is switched on then the equipment will not start joint-tracking for safety reasons. To start joint-tracking, another position must be briefly selected before returning to the required position.



**Control lever**

- Manual control of servo slides Up/Down and Left/Right.

The control lever is always overriding.





When the alarm lamp   is illuminated the downward manual movement is blocked.



Selection of low or high speed during manual positioning with the control lever.

- One press on the button activates rapid speed.  
A lamp in the button illuminates when the function is activated.
- Return to low speed by pressing the button again  
Check that the lamp has gone out before carrying out further commands.

### 4.3 Joint-tracking unit - rear section

1		Connection, power supply 42 V
2		Switch Power supply On/Off
3		Switch For switching the horizontal slide motor's direction of movement.
4		Socket, for connecting the vertical slide motor
5		Socket, for connecting the horizontal slide motor
6		Control fuse, 10 A slow
7		Sleeve socket (8-pin), for connecting the guide finger.
8		Socket (23-pin), for connecting the portable control box.
9		Sockets, for connecting the limit position switch
10		Extra sockets
11		Service contacts

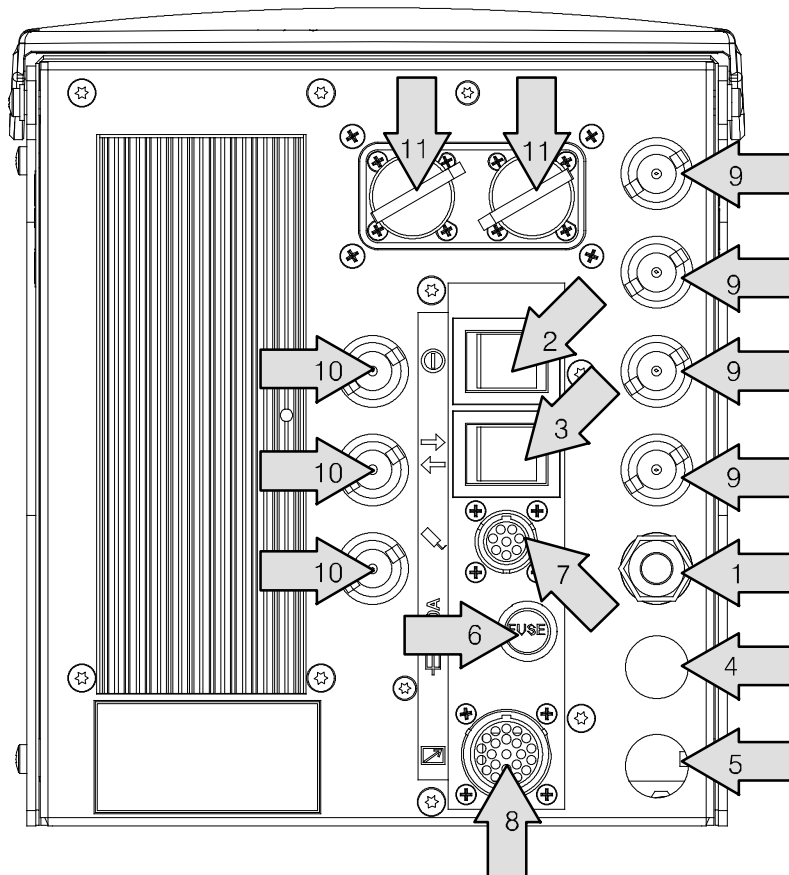

#### 4.4 Portable control box

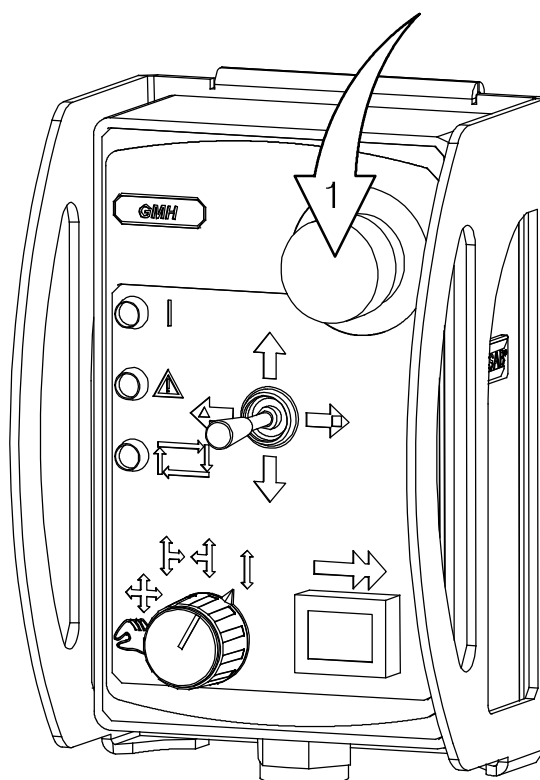

##### **Emergency stop (1)**

- One press on the button activates EMERGENCY STOP

**NB!** An emergency stop must never be reset before the cause of the abnormal function or signal has been established and rectified.

**Signal lamp**   (white)

- Illuminates when the power has been switched on.

**Alarm lamp (automatic joint-tracking)**   (yellow)

- Illuminates when the guide finger is outside the working range (vertical). The automatic function is then blocked.



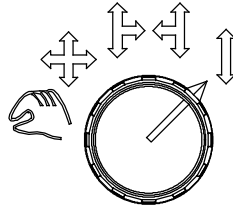

**Signal lamp (joint-tracking)**   (green)

- Illuminates when automatic joint-tracking is in progress.



**Switch with 5 positions**

Selection of joint-tracking and joint-searching options:



- Manual preset - Position 
- Vertical and horizontal joint-tracking - Position 
- Vertical and horizontal joint-tracking with joint-searching to the right - Position 
- Vertical and horizontal joint-tracking with joint-searching to the left - Position 
- Vertical joint-tracking - Position 

**NOTE!**

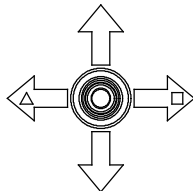
If the switch is in a joint-tracking position when the equipment is switched on then the equipment will not start joint-tracking for safety reasons. To start joint-tracking, another position must be briefly selected before returning to the required position.



**Control lever**

- Manual control of servo slides Up/Down and Left/Right.  
The control lever is always overriding.  
When the alarm lamp   is illuminated the downward manual movement is blocked.

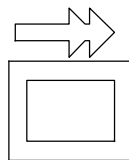

**Lamp pushbutton (rapid speed)**

Selection of low or high speed during manual positioning with the control lever.

- One press on the button activates rapid speed.  
A lamp in the button illuminates when the function is activated.
- Return to low speed by pressing the button again  
Check that the lamp has gone out before carrying out further commands.





## 4.5 Joint-tracking

The joint-tracking equipment can be set for different types of joint-tracking. It can be set for joint-tracking with edge control and for joint-tracking with groove control. The setting is made both on the control box and on the sensor.

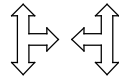
### 4.5.1 Joint-tracking with edge control



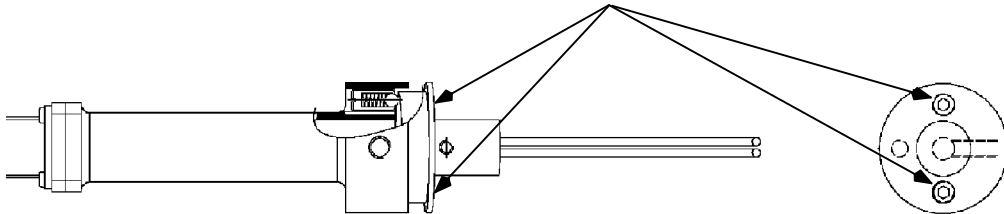

The following functions are set on the control box,  or  depending on whether right or left-hand control is required. The two stop screws on the sensor should be screwed in to the stop point. See the illustration below. This means that the fuses are spring-loaded laterally and edge control is allowed. Joint-tracking with edge control is used for welding fillet welds and similar joints, see also the joint table on page 18.

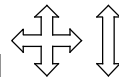

*The stop screws are tightened to the stop point.*

### 4.5.2 Joint-tracking with groove control





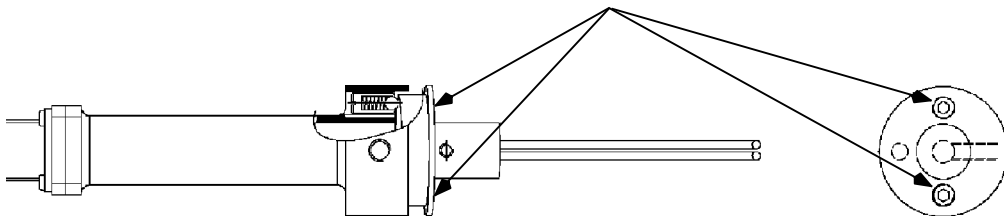















The following functions are set on the control box,  or  depending on whether both vertical and lateral control or just vertical control are required. The stop screws on the sensor must be screwed out at least two turns or to the stop point, see the illustration below. This releases the spring loading for the search fingers laterally and enables groove control. If the stop screws are not screwed out then there is a risk that the search fingers start to "climb" up the joint walls in shallow V and U-joints. See also on page 18 for selection of setting.



*The stop screws screwed out 2 turns*

Examples of different types of joint and of the guide finger's application against the guiding edges.

	Joint type	Setting, control box
Double flanged butt weld		
I-weld (A=guide bar)		
V-weld		
1/2 V-weld		
1/2 V-weld		
U-weld		
Double U-weld		
J-weld		
Double J-weld		

X-weld



Asymmetrical X-weld



K-weld



K-weld



Fillet weld

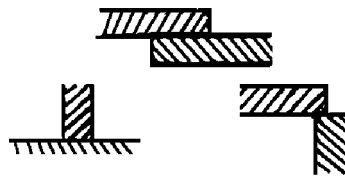

### 4.6 Positioning for welding start

1. Align the welding equipment into position in relation to the weld joint so that the working range of the slide cross covers the whole height and lateral deviation of the joint from starting point to the stopping point for welding.

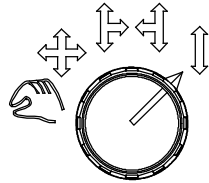

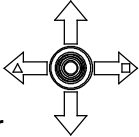

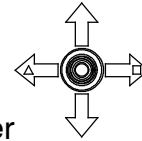
2. Set the switch  in the required joint-tracking position.

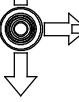

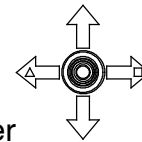
3. Operate the guide finger horizontally using the control lever , until the finger is above a suitable start position, see the figure below. For vertical joint-tracking alone the guide finger is positioned where the start of the weld is required to be.

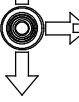

4. Operate the welding head downwards with the control lever , until the signal lamp  goes out.

The equipment now searches for the ideal position itself vertically and horizontally if horizontal joint-tracking is activated.

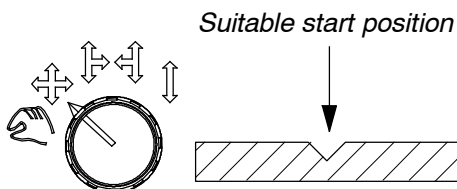
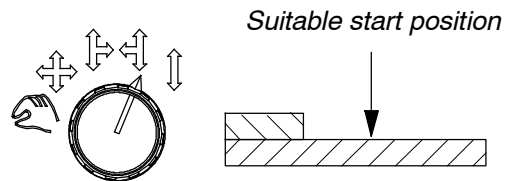
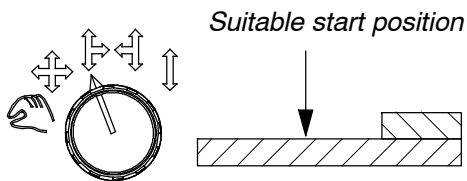

### 4.7 Positioning for welding start (with inductive joint-tracking)

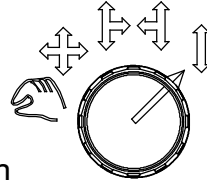

The product must be configured before inductive joint-tracking is possible. Please refer to ESAB's service department for configuration.

1. Align the welding equipment into position in relation to the weld joint so that the working range of the slide cross covers the whole height and lateral deviation of the joint from starting point to the stopping point for welding.

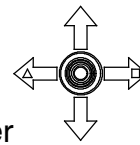

2. Set the switch in the vertical joint-tracking position



3. Position the sensor downwards with the control lever , until the signal lamp   goes out.

The equipment now searches for the ideal position itself vertically.

**N.B.** If only vertical joint-tracking shall be used, skip the following points.

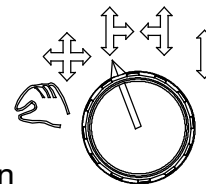

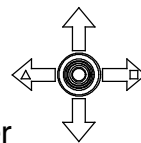

4. Set the switch in the vertical-right joint-tracking position

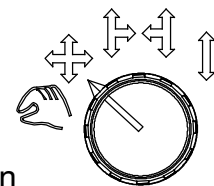

5. Position the sensor using the control lever horizontally to the ideal position until the signal lamp   goes out.



6. Set the switch in the vertical-horizontal joint-tracking position

The signal lamp goes out.   The equipment searches for the ideal position itself horizontally and vertically. If the signal lamp does not go out repeat the procedure from Step 1.

---

## 5 MAINTENANCE

---

### 5.1 General

**Note:**

*All warranty undertakings given by the supplier cease to apply if the customer attempts to rectify any faults on the machine during the warranty period.*

- Check daily that the guide fingers are not worn or damaged.
- Clean the sensor with compressed air regularly.
- Follow the instructions for the internal components.
- Please refer to ESAB's service department for tuning the system.

### 5.2 Wear parts

#### Tracking fingers

Part no. 146 586-001

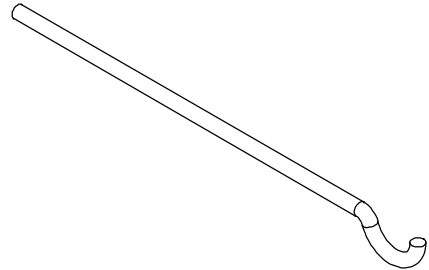

---

## 6 ORDERING OF SPARE PARTS

---

Spare parts are ordered through your nearest ESAB representative, see back cover. When ordering spare parts, please state machine type and number as well as designation and spare part number as shown in the spare parts list on page 211. This will simplify dispatch and ensure you get the right part.

## **7 ACCESSORIES**

	<b>Ordering number:</b>
Intermediate transformer for separate power supply, from mains power 190, 220, 380, 415, 440, 500V 50 Hz 200, 230, 380, 415, 440, 500V 60 Hz to secondary 42V, 660 VA	0148636002
Cable 3 x 2.5 mm <sup>2</sup> , connection, transformer	0262613404
A6 servo slide ball bushing type with permanent magnetised motor 42 V DC	0334333xxx
A6 motor driven slide, slide bearing mounted long runner, with A6 VEC motor 42V - 4000 rpm ratio 74:1	0334426xxx
Motor cable The cable is available in different lengths, see the appropriate sales brochure for the servo slide (contact ESAB's sales office)	0460745xxx
Finger with ball (L=100 mm)	0416719001
Finger for internal and external corner	0418091880
Sensor cable with 90° contact (2 m)	0417346887
Protective rubber bellows	0412013001
Console for control box (the console is available in different versions)	0433762xxx
Counterbalance plate for cables	0460861880

DIAGRAM ΣΧΗΜΑ ΣΥΝΔΕΣΗΣ SCHEMAT KAPCSOLÁSI RAJZ SCHEMA  
 SCHÉMA SHĪMA SCHEMA SHEME DIAGRAMÁ

GMH with control panel

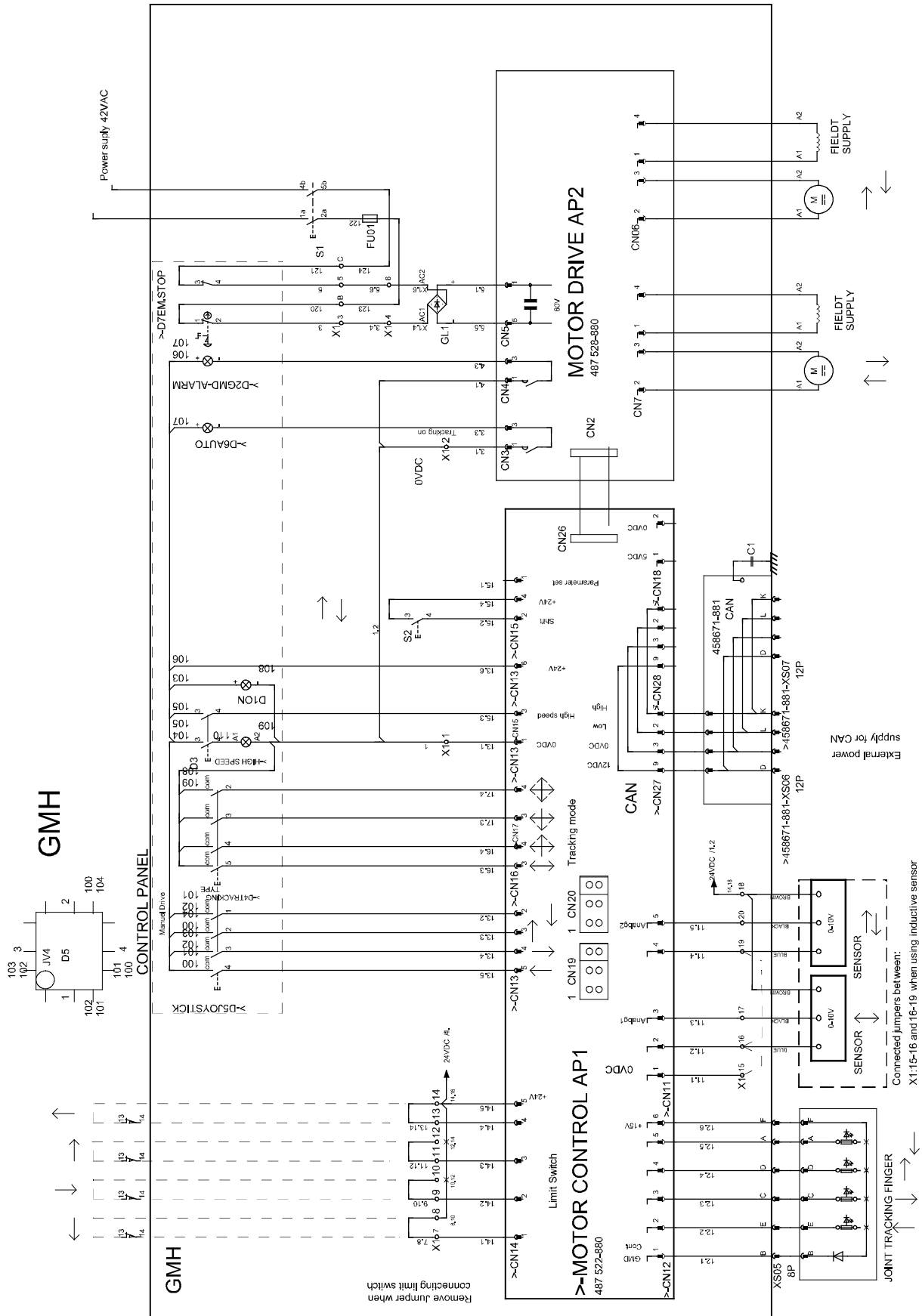



# GMH with portable control box

## GMH

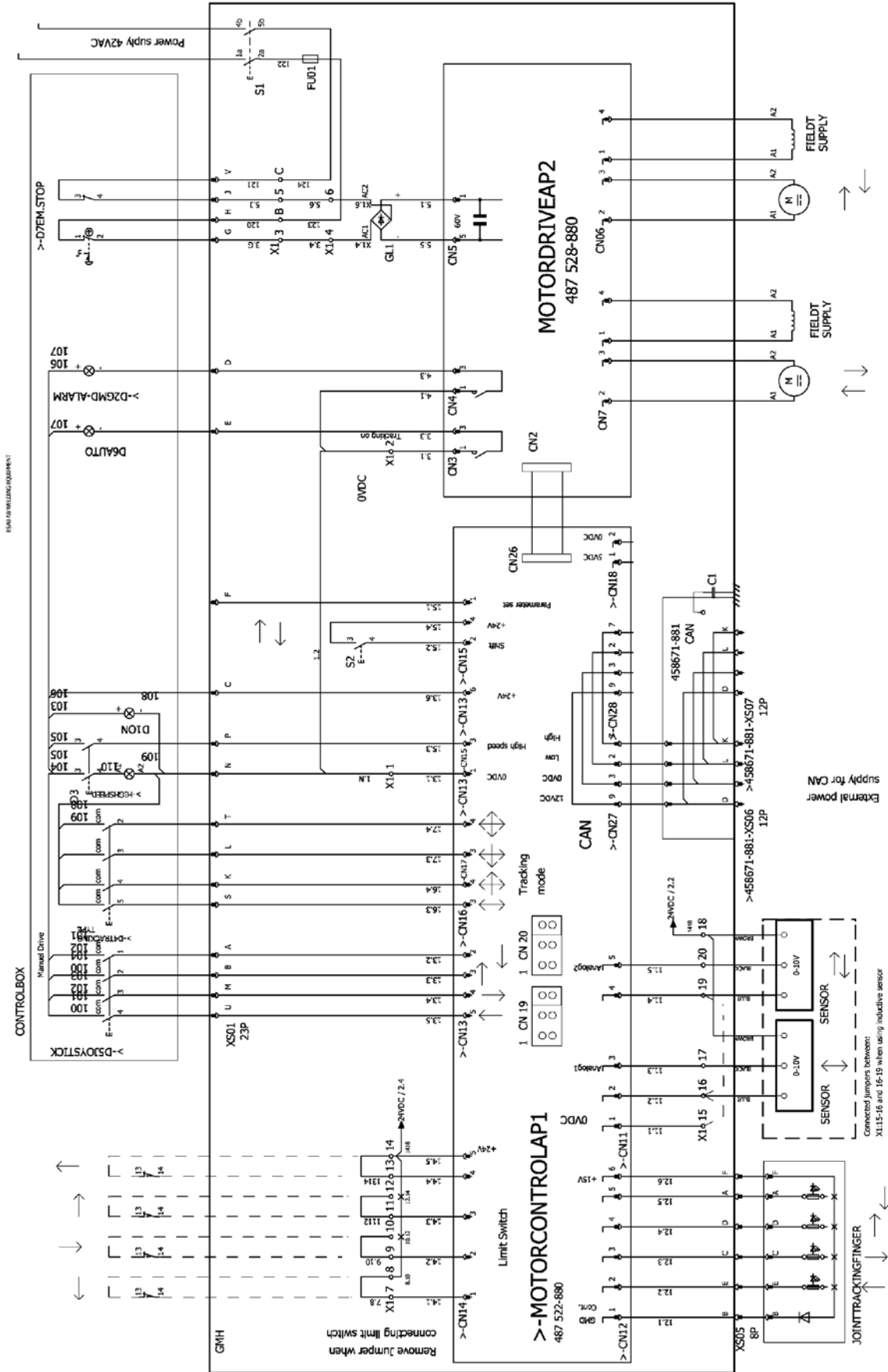



**DIMENSION DRAWING ΣΧΕΔΙΑΡΑΜΜΑ ΜΕΓΕΘΩΝ RYSUNEK  
 WYMIAROWANYMÉRETEZETT RAJZ ROZMĚROVÝ VÝKRES ROZMEROVÝ  
 VÝKRES RASĚJUMI AR IZMÉRIEM MATMENŮ BRĚŽINYS KOTIRANE  
 NACRTE DESEN DIMENSIONAL**

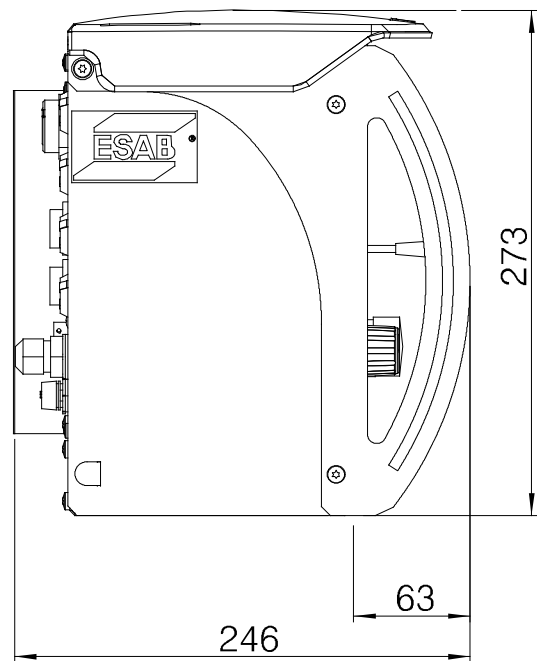
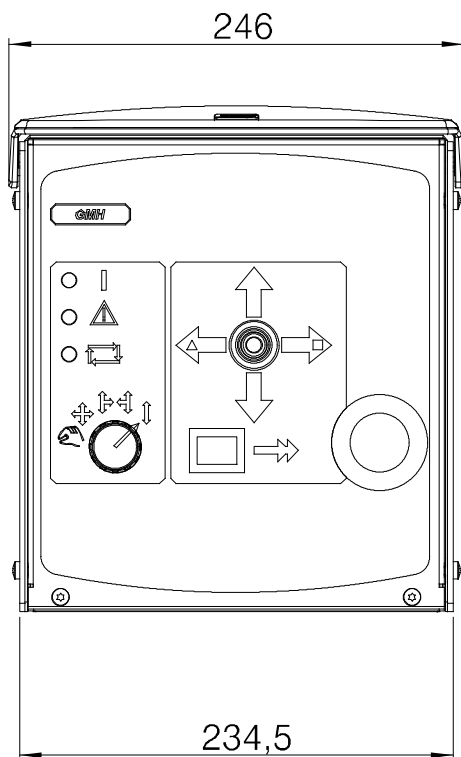
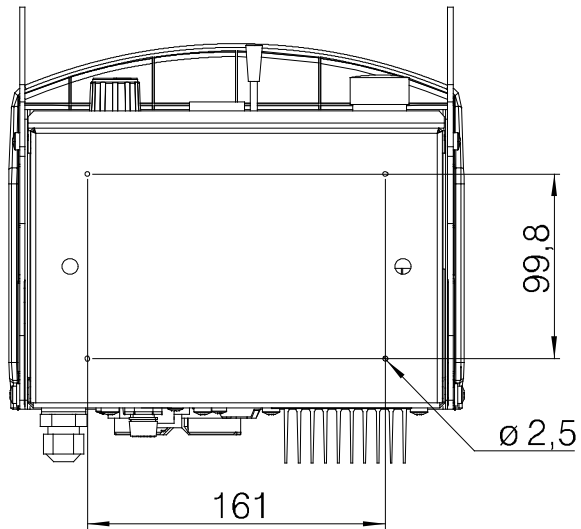

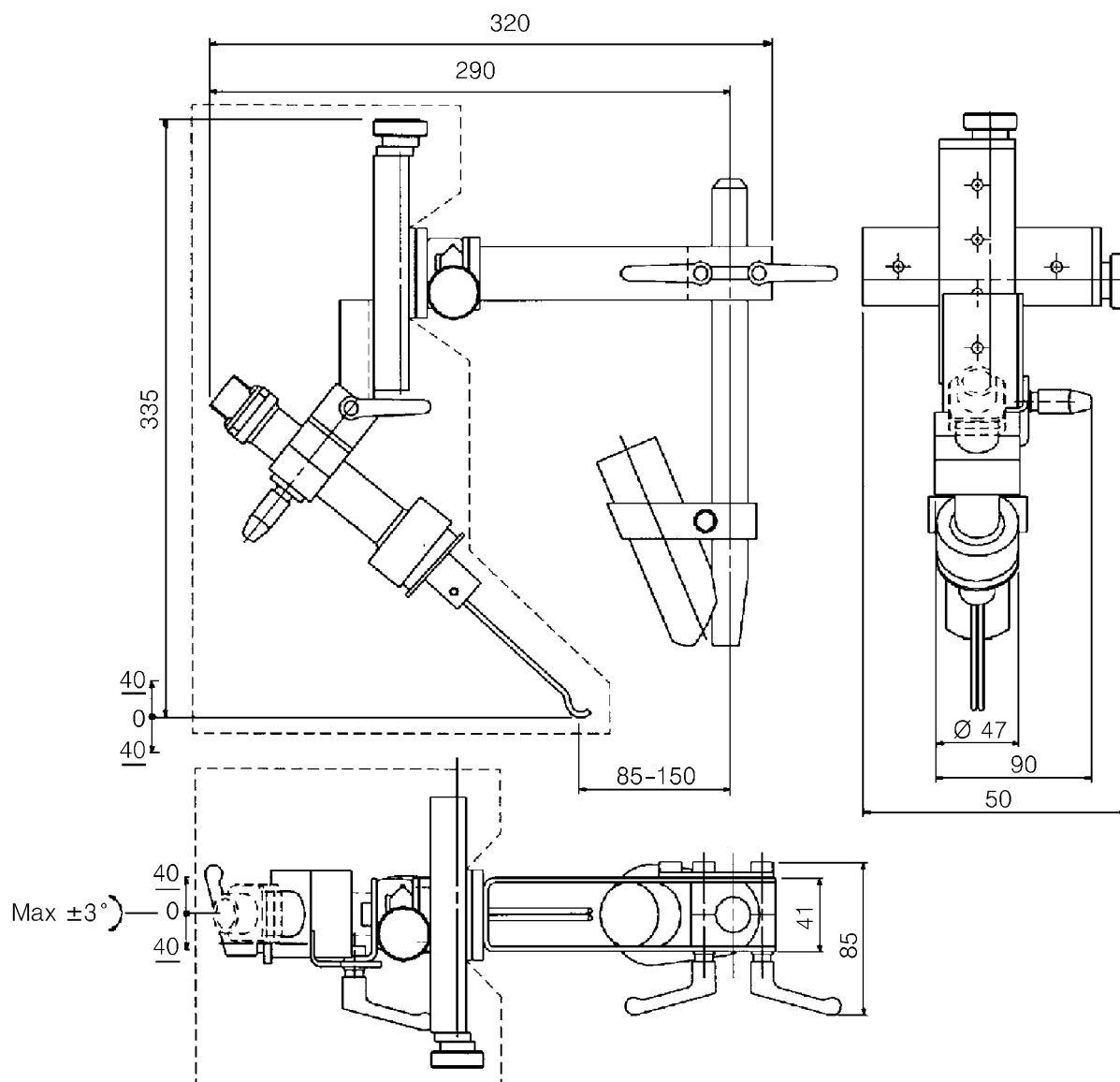

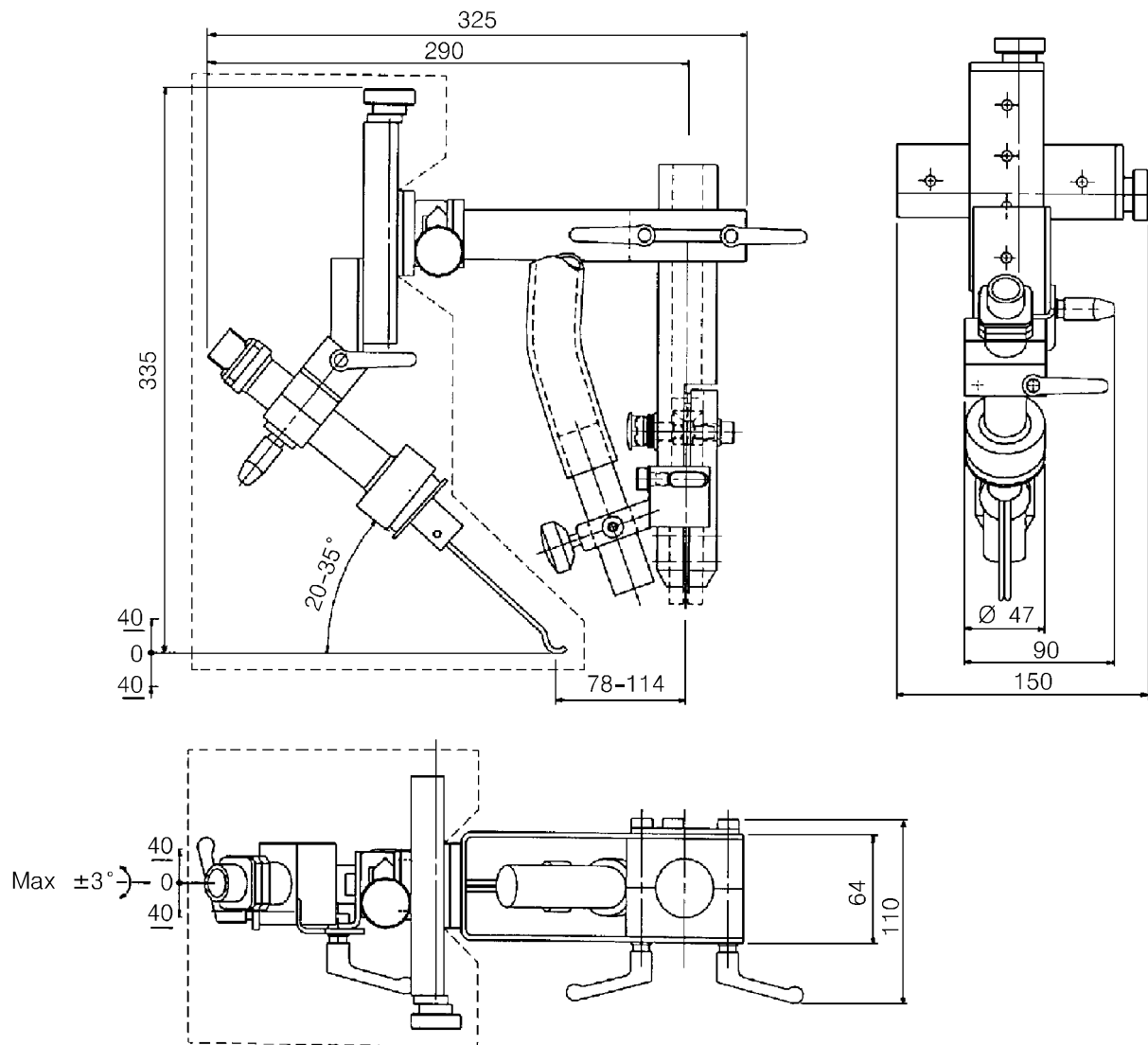



SPARE PARTS LIST ΠΙΝΑΚΑΣ ΑΝΤΑΛΛΑΚΤΙΚΩΝ ΜΕΡΩΝ SPIS CZĘŚCI  
 ZAPASOWYCH TARTALÉKALKATRÉSZLISTA SEZNAM NÁHRADNÍCH DÍLŮ  
 ZOZNAM NÁHRADNÝCH DIELOV REZERVES DAŁU SARAKSTS ATSARGINIŲ  
 DALIŲ SĄRAŠAS POPIS PRIÉUVNIH LISTA DE PIESE DE SCHIMB

Edition 2012-04-16

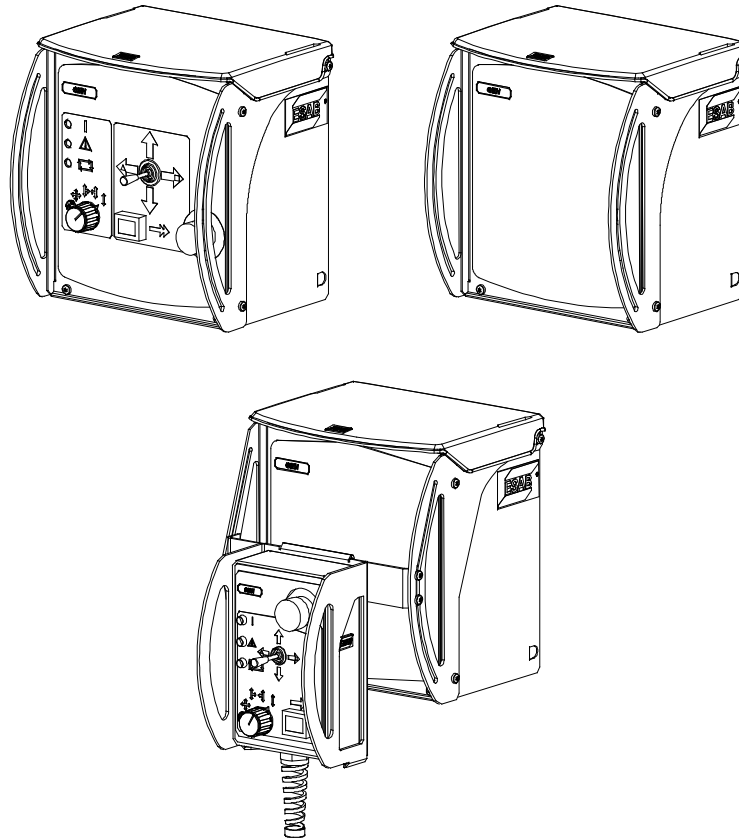

Ordering no.	Denomination	Notes
0460503880	GMH Complete	Joint tracking unit without control panel
0460503881	GMH with MMC Complete	Joint tracking unit with control panel
0460698880	GMH with portable control box	Joint tracking unit without control panel and with portable control box
0460570880	Portable control box	
0416688880	Sensor	
0416739880	Slide cross for sensor	
0821425880	Slide cross for sensor and laser lamp	

Item no.	Qty	Ordering no.	Denomination	Notes					
		<b>0460503880</b>	<b>GMH</b>	<b>Without control panel</b>					
1	1	0460468880	Basic module						
2	1		Outlet module, GMH portable control	See separate part page 236					
3	1	0460462880	MMC without controls						
4	7	0194292020	Grommet	Ø20					
5	4		Screw MRT, ground-cutter (black)	M5x12					
6	6		Screw MRT (black)	M5x16	12	1	0460673880	Supply cable	L = 5m
12	1	0460673880	Supply cable	L = 5m					

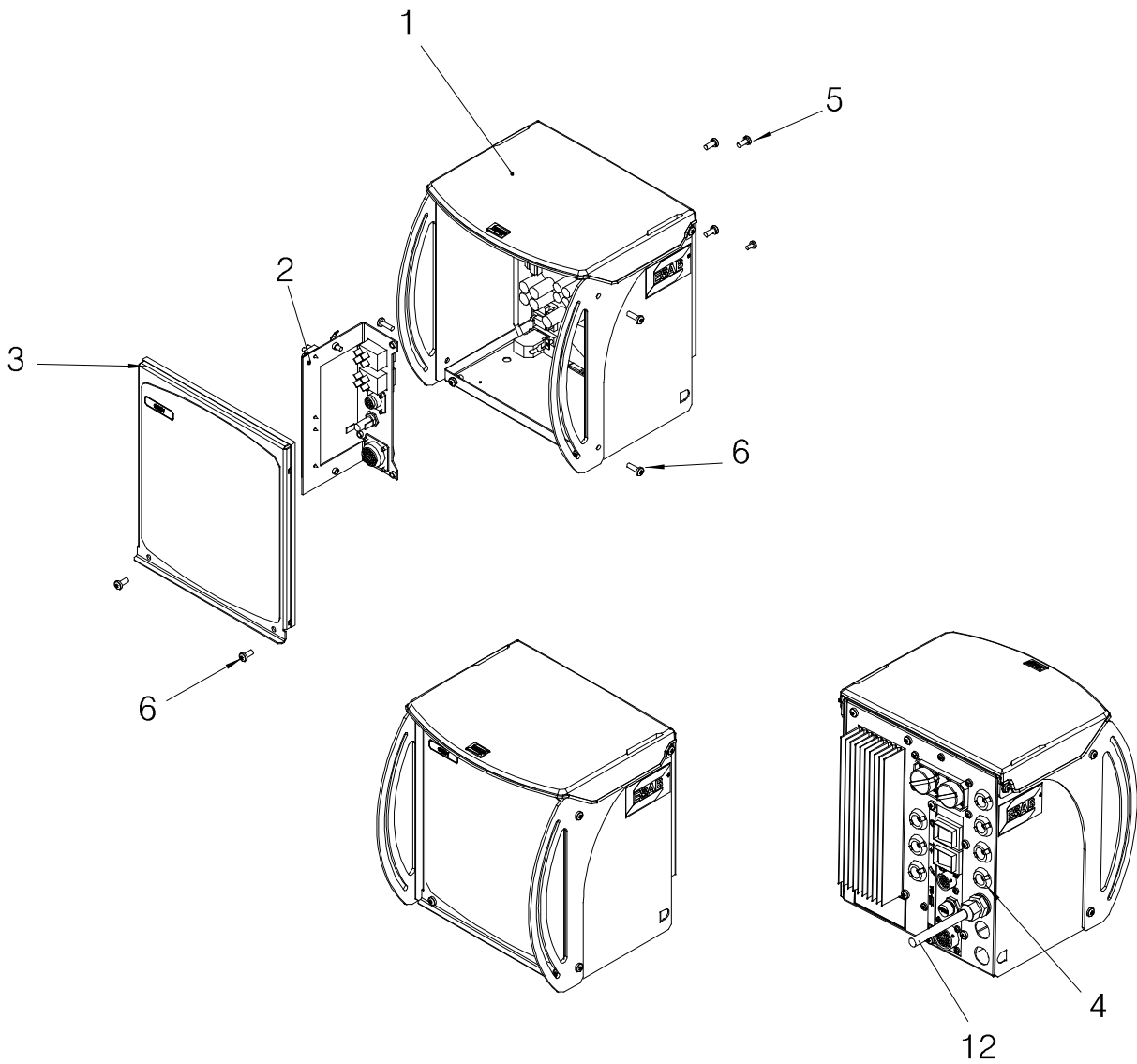



Item no.	Qty	Ordering no.	Denomination	Notes					
		<b>0460503881</b>	<b>GMH with MMC</b>	<b>With control panel</b>					
1	1	0460468880	Basic module						
2	1		Outlet module, GMH MMC	See separate part page 236					
3	1	0460462882	MMC GMH						
4	7	0194292020	Grommet	Ø20					
5	4		Screw MRT, ground-cutter (black)	M5x12					
6	6		Screw MRT (black)	M5x16	12	1	0460673880	Supply cable	L = 5m
12	1	0460673880	Supply cable	L = 5m					

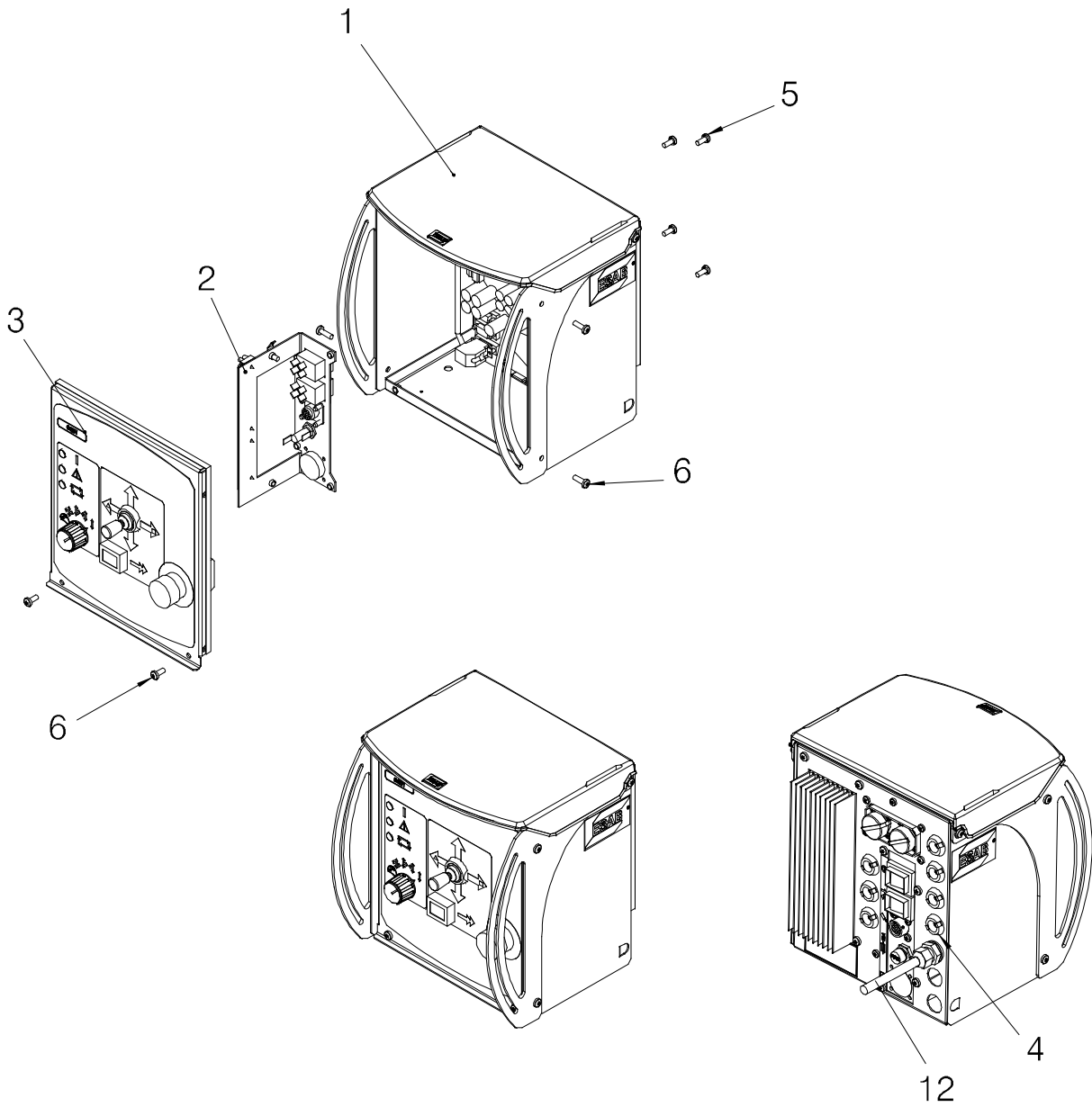

Item no.	Qty	Ordering no.	Denomination	Notes
		<b>0460468880</b>	<b>Basic module</b>	
2	1	0458679885	Operating contact can tractor	
3	4		Screw RX-PT	6-19x8
4	6		Screw MRT ground-cutter	M5x12
5	8		Screw MRT	M4x8, DIN 7985
7	2	0460465001	Spacer for hinge	
8	2	0460463001	Protective frame	
9	1	0460430001	Cover	
10	1	0460469001	Sun visor	
12	2		Screw MRT (black)	M5x16
15	1		Circuit board module	see on page 235

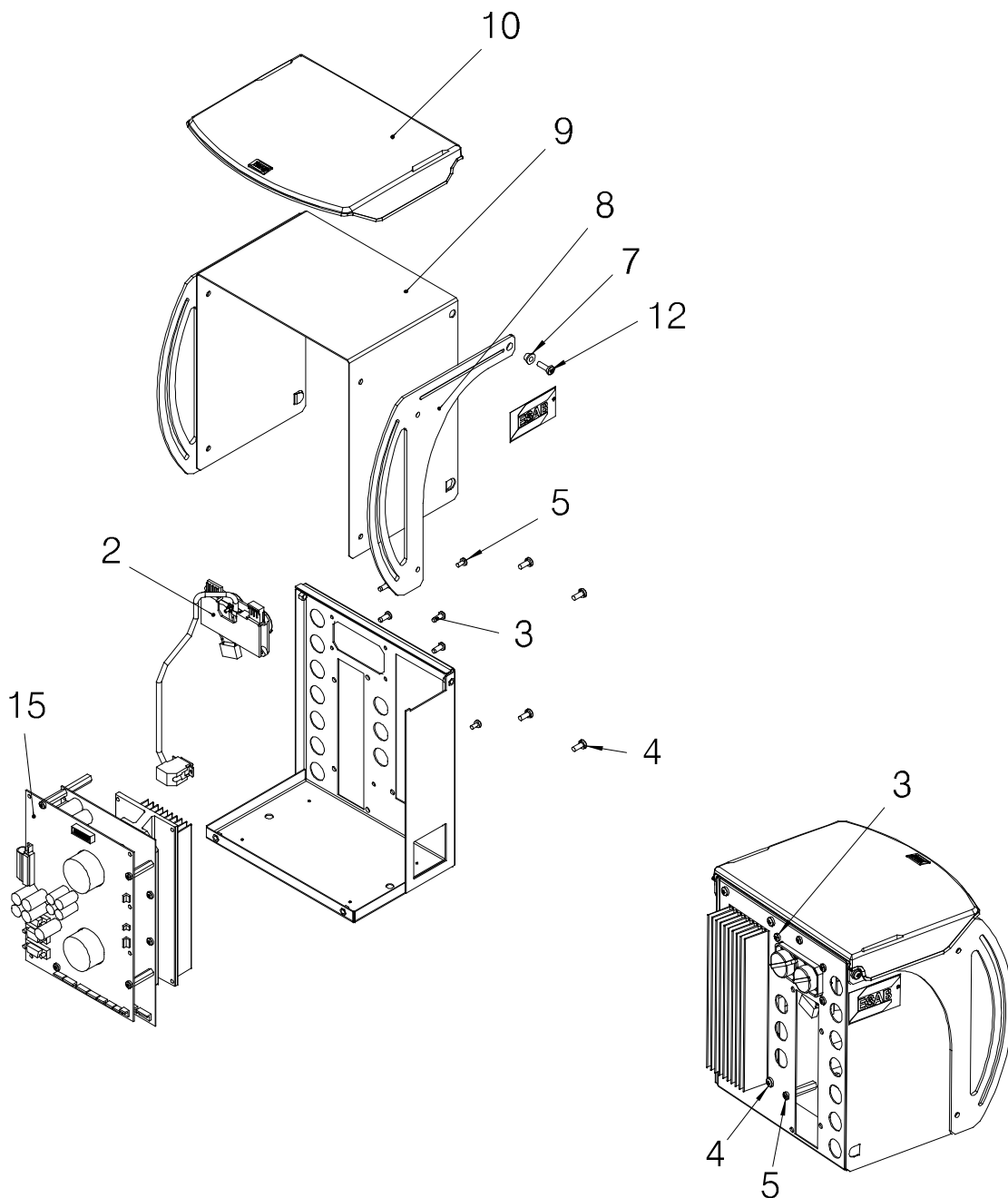

Item no.	Qty	Ordering no.	Denomination	Notes
			<b>Circuit board module</b>	
1	1	0460461001	Heat sink	GMH GMH with inductive sensor  26-pole
2	1	0487528881	PC board, motor drive	
3	1	0487522981	PC board, motor control	
		0487522982	PC board, motor control	
8	1	0460648880	Cable set with rectifier bridge	
9	2		Spring washer	
11	1	0193700703	Ribbon cable+connectors	

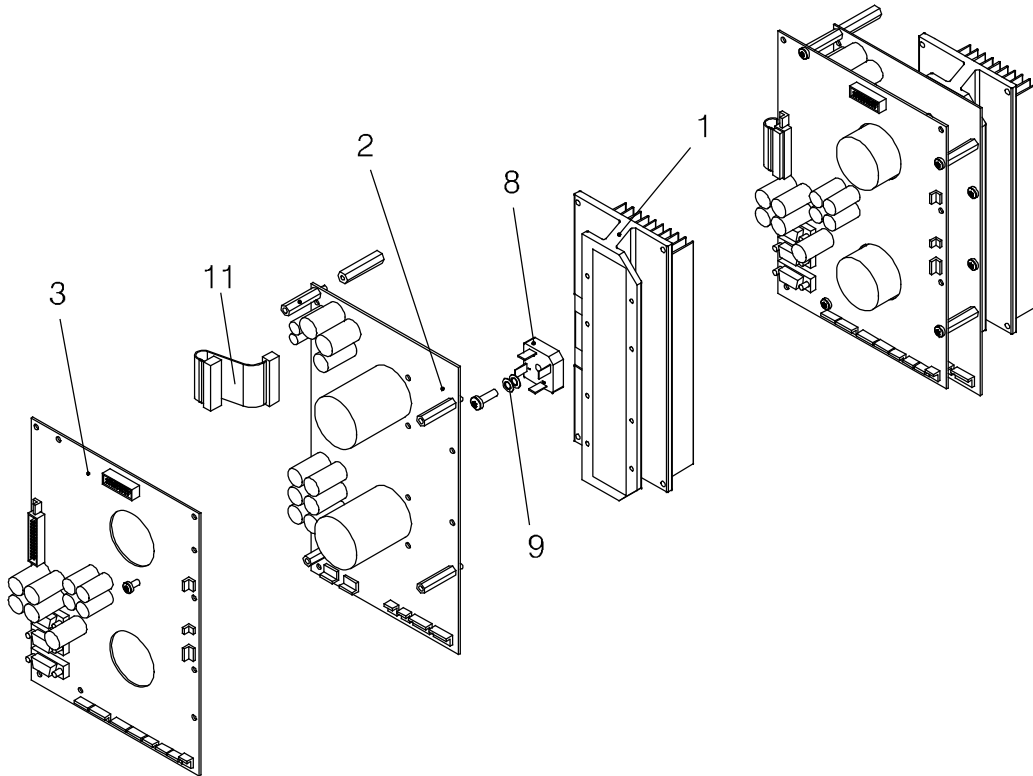

Item no.	Qty	Ordering no.	Denomination	Notes
			<b>Outlet module, GMH portable control box</b>	<b>GMH</b>
2	1		Screw MRT ground-cutter	M5x12
3	1		Flat pin	6,3x0,8 M6
5	2		Screw RTS	st2,9x13
6	8		Screw RX-PT	6-19x8
7	1	0193701001	Fuse holder	fine.5x12
8	1	0193701002	Fuse holder	5x20
9	1	0567900116	Fuse	10 A (Slow)
10	2	0193317001	Switch	
14	1	0368544004	Contact	Burndy, 8-pole
20	1	0368544005	Contact	Burndy, 24-pole
			<b>Outlet module, GMH MMC</b>	<b>GMH</b>
2	1		Screw MRT ground-cutter	M5x12
3	1		Flat pin	6,3x0,8 M6
5	2		Screw RTS	st2,9x13
6	4		Screw RX-PT	6-19x8
7	1	0193701001	Fuse holder	fine.5x12
8	1	0193701002	Fuse holder	5x20
9	1	0567900116	Fuse	10 A (Slow)
10	2	0193317001	Switch	
14	1	0368544004	Contact	Burndy, 8-pole

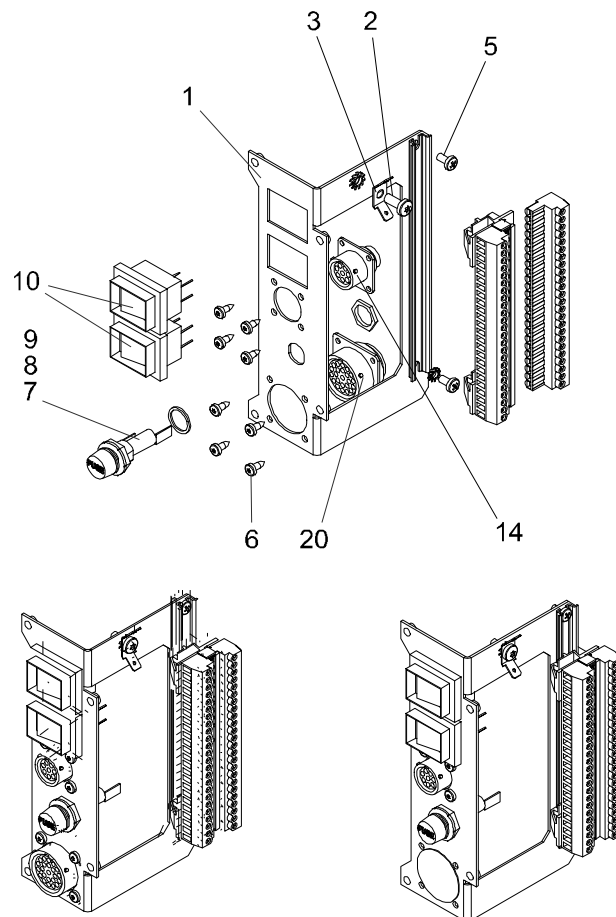

Item no.	Qty	Ordering no.	Denomination	Notes
		<b>0460462882</b>	<b>MMC GMH</b>	<b>GMH</b>
4	1	0194282001	LED (white)	24 V
5	1	0194282002	LED (yellow)	24 V
6	1	0194282003	LED (green)	24 V
7	1	0460600328	Knob, grey with arrow	d28-6mm
			<b>Cable set GMH with MMC</b>	
404	2	0415200020	Contact block 1no+1nc	1no+1nc
405	1	0415200027	Cap orange	18x24
406	1	0415200001	Push-button	18x24
407	1	0415200047	Bulb	14V 80mA
408	1	0415200058	Splash water shield	
409	1	0460424881	Emergency stop	
410	1	0460795001	Joy-stick	
411	1	0192722004	Switch	5 settings

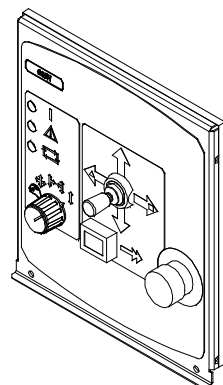
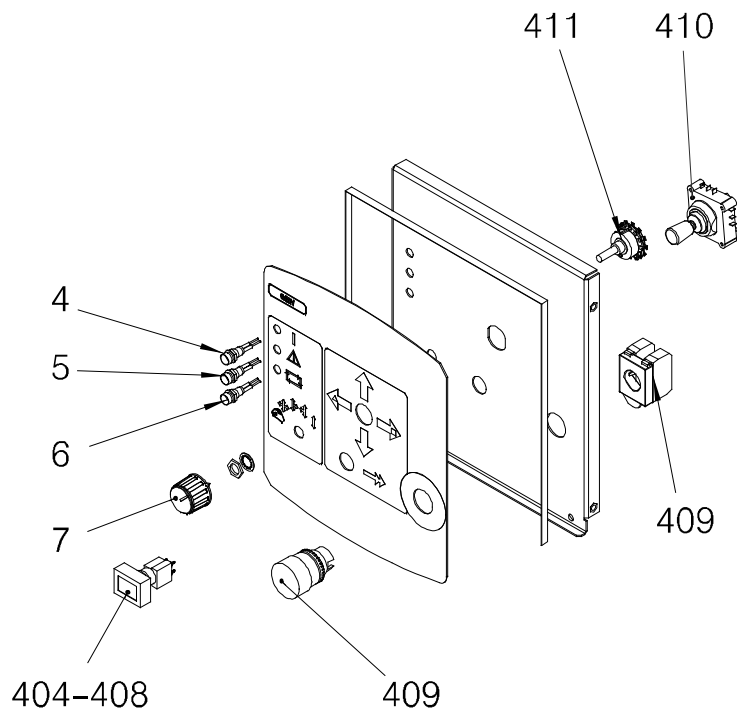

Item no.	Qty	Ordering no.	Denomination	Notes
		<b>0460698880</b>	<b>GMH with portable control box</b>	
1	1	0460503880	GMH without MMC	
2	1	0460570880	Portable control box	
3	1	0460481001	Bracket	
4	4		Screw (Black)	MRT M5x16

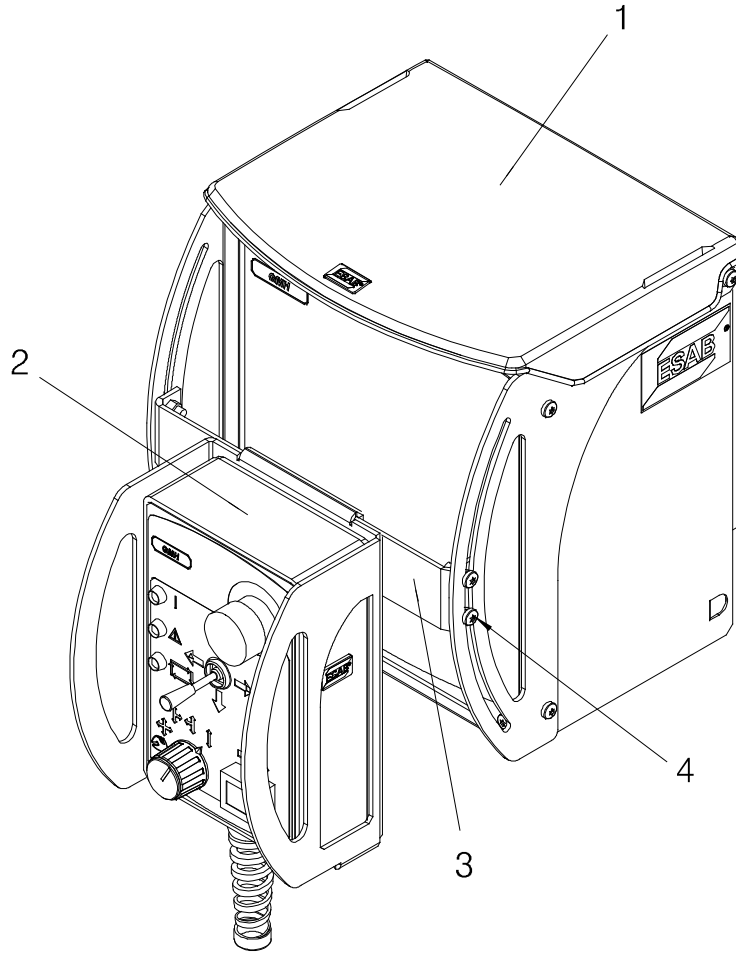

Item no.	Qty	Ordering no.	Denomination	Notes
		<b>0460570880</b>	<b>Portable control box</b>	<b>GMH</b>
2	1	0194282001	LED indicator white	
3	1	0194282002	LED indicator yellow	24 V
4	1	0194282003	LED indicator green	24 V
5	1	0460424881	Emergency stop complete	
6	1	0460795001	Joy-stick	
7	1	0194055009	Switch	5 settings
10	1	0460569001	Cover	
13	1	0460600328	Knob, grey with arrow	d28-6mm
15	1	0460759880	Remote cable	4m
16	1		Nut	pr22,5
17	6		Screw	MFX-PH M4x16
20	1	0415200020	Contact block	1NO+1NC
21	1	0415200033	Cap orange	18x18
22	1	0415200002	Push button	18x18
23	1	0415200048	Bulb	28V 40mA
24	1	0391844022	Splash water shield	

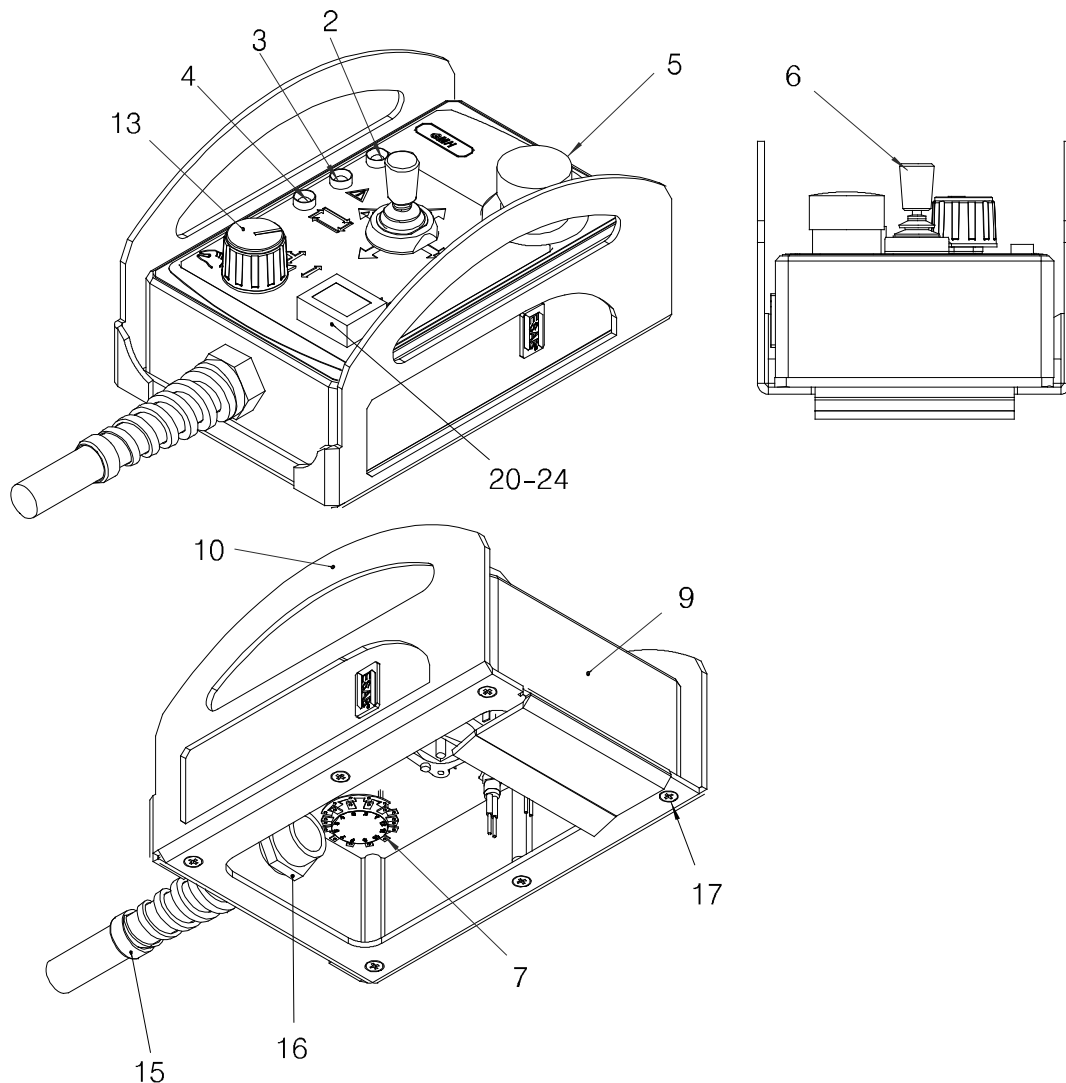

Item no.	Qty	Ordering no.	Denomination	Notes
		<b>0460759880</b>	<b>Remote cable</b>	<b>4m</b>
1	4	0193963002	Cable screened	6x1,5mm2 12x0,5mm2
2	1	0193307105	Cable fitting	stp-b 16
3	1	0194200023	Cable gland with tube	23-pole
4	1	0194182023	Pin plug	23-pole
5	11	0323945001	Connector pin	rm20m-13k
6	6	0323945004	Connector pin	rm16m-23k

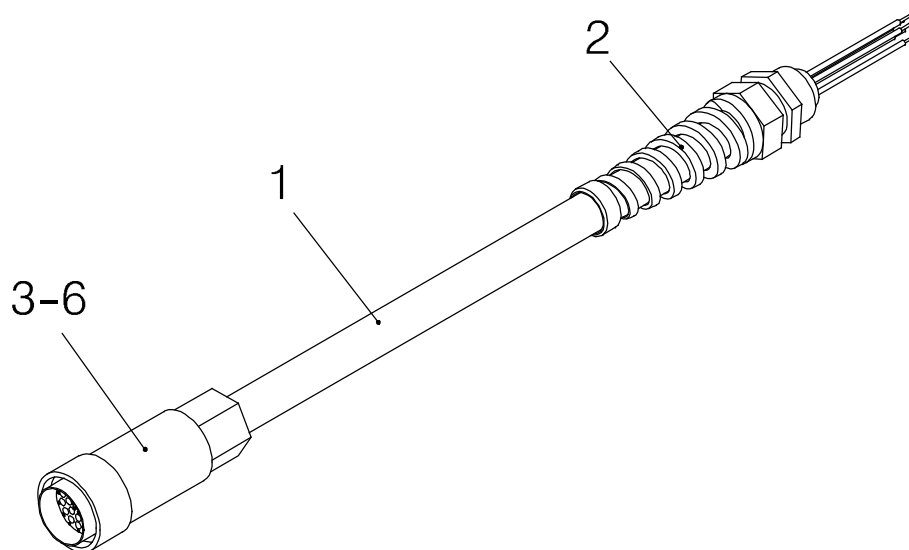



Item no.	Qty	Ordering no.	Denomination	Notes
		<b>041668880</b>	<b>Sensor</b>	
2	1	0156106880	Joint tracking sensor	
3	1	0415836880	Diffusor	
4	1	0415739001	Insulation	t 0,125
5	1	0417258880	Sleeve	d45
6	1	0416671001	Guide arm	d18
7	1	0415328001	Yoke	
8	1	0211101049	Pin	d3x18
9	2	0193860109	Pressure pin reinforced	m8x16
11	1	0417958880	Ring with adjustable screw	
13	1	0415329001	Guide arm attachment	
15	2	0146586001	Guide finger	
21	1	0415332002	Seal	
22	1	0418090001	Pressure spring	
24	1	0412013001	Safety bellows	

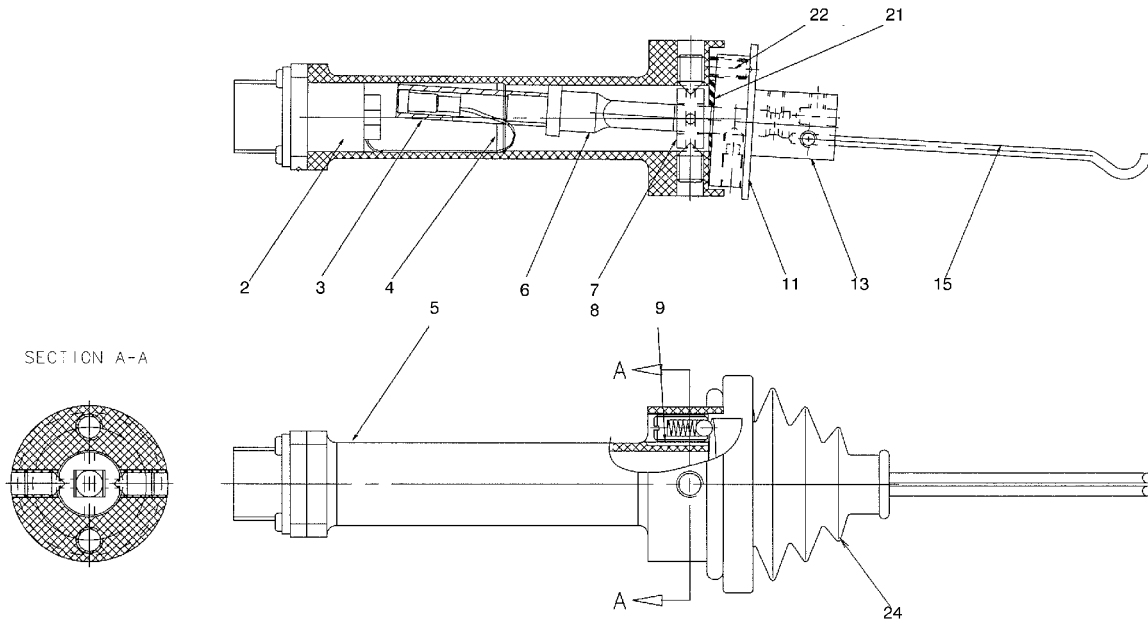

Item no.	Qty	Ordering no.	Denomination	Notes
		<b>0416739880</b>	<b>Slide cross for sensor</b>	
3	1	0413366112	Clamp	D25
6	3	0193570120	Locking lever	m6x50x63
8	1	0193570109	Locking lever	m6x16x45
10	2	0433851001	Mini slide	
12	1	0413366115	Clamp	D35
13	2	0193570150	Locking lever	m6x75
15	1	0413366320	Clamp	D20
18	1	0417096880	Mounting bracket	
19	1	0417097001	Clamp	
20	1	0417098880	Mounting bracket	
21	1	0417099880	Plate	
22	1	0417097002	Clamp	

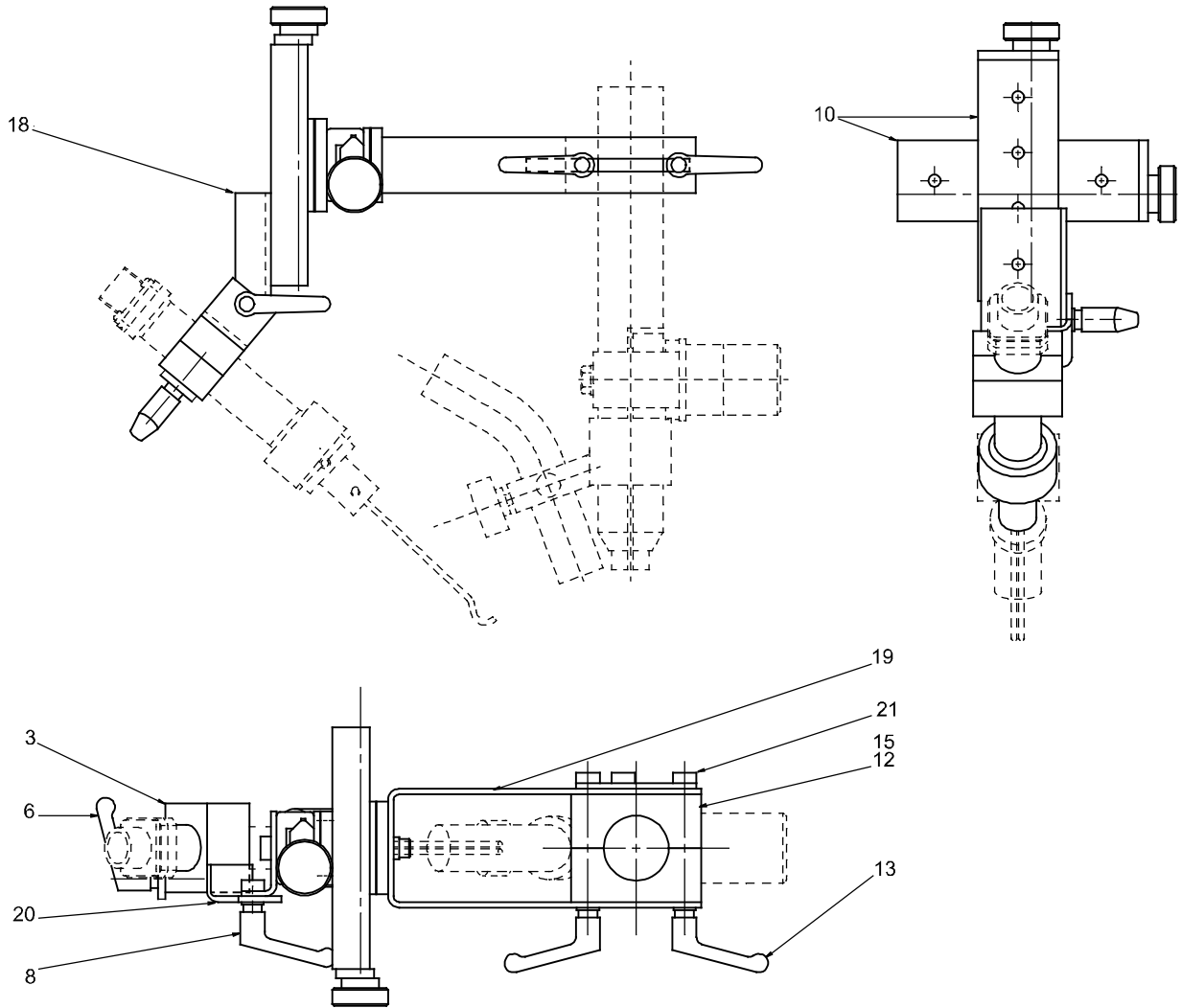

Item no.	Qty	Ordering no.	Denomination	Notes
		<b>0821425880</b>	<b>Slide cross for sensor+laser lamp</b>	
2	1	0413366112	Clamp	
5	2	0193570120	Locking arm adjustable	
7	1	0193570109	Locking arm adjustable	m6
9	2	0433851001	Mini slide	
11	1	0413366115	Clamp	70x58x30 d35
12	2	0193570150	Locking arm adjustable	m6x75
13	1	0417096880	Mounting bracket	
14	1	0417098880	Angle bracket	
15	1	0417099880	Plate for slide cross	
18	1	0821423001	Clamp	
20	1	0818935001	Clamp	vh 25
22	4	0219504303	Cup	d12.5/6.2

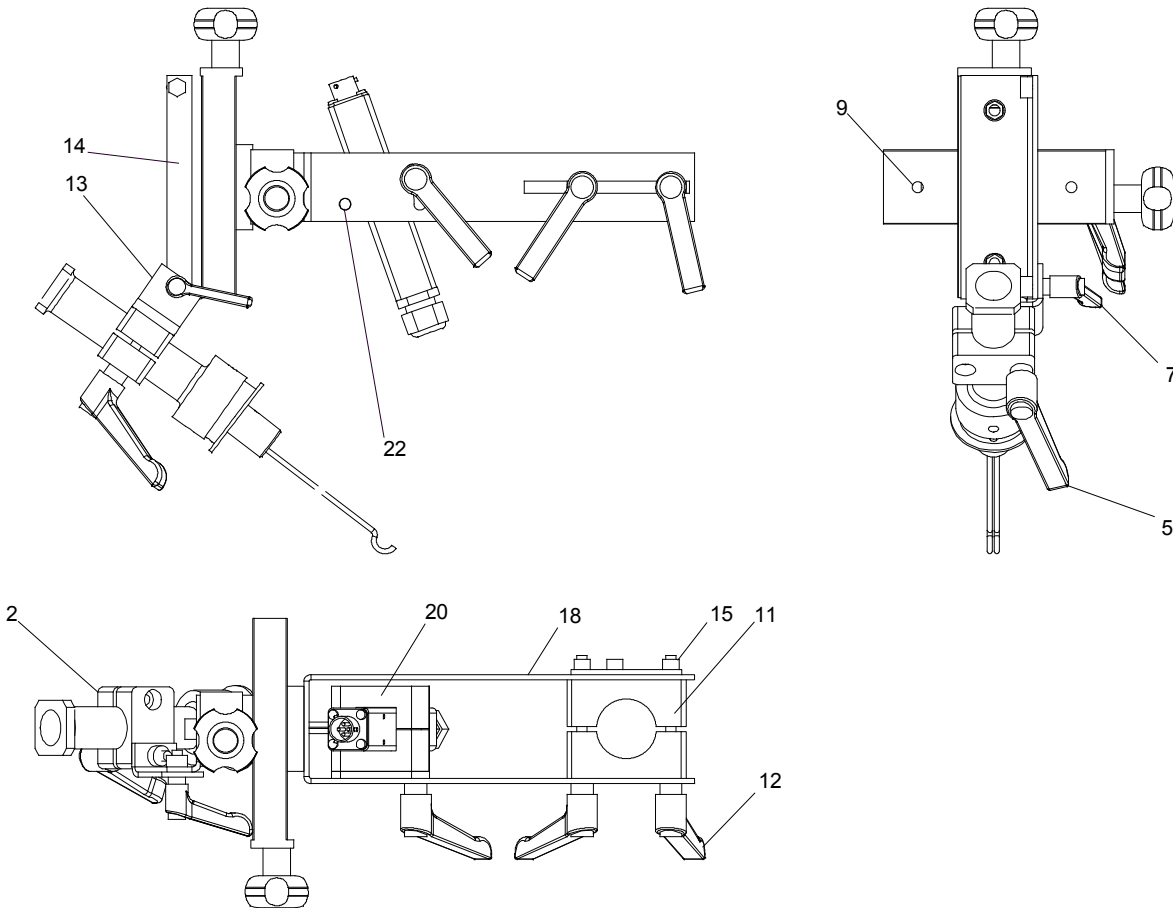

# ESAB subsidiaries and representative offices

<b>Europe</b> <b>AUSTRIA</b> ESAB Ges.m.b.H Vienna-Liesing Tel: +43 1 888 25 11 Fax: +43 1 888 25 11 85 <b>BELGIUM</b> S.A. ESAB N.V. Brussels Tel: +32 2 745 11 00 Fax: +32 2 745 11 28 <b>BULGARIA</b> ESAB Kft Representative Office Sofia Tel/Fax: +359 2 974 42 88 <b>THE CZECH REPUBLIC</b> ESAB VAMBERK s.r.o. Vamberk Tel: +420 2 819 40 885 Fax: +420 2 819 40 120 <b>DENMARK</b> Aktieselskabet ESAB Herlev Tel: +45 36 30 01 11 Fax: +45 36 30 40 03 <b>FINLAND</b> ESAB Oy Helsinki Tel: +358 9 547 761 Fax: +358 9 547 77 71 <b>FRANCE</b> ESAB France S.A. Cergy Pontoise Tel: +33 1 30 75 55 00 Fax: +33 1 30 75 55 24 <b>GERMANY</b> ESAB GmbH Solingen Tel: +49 212 298 0 Fax: +49 212 298 218 <b>GREAT BRITAIN</b> ESAB Group (UK) Ltd Waltham Cross Tel: +44 1992 76 85 15 Fax: +44 1992 71 58 03 ESAB Automation Ltd Andover Tel: +44 1264 33 22 33 Fax: +44 1264 33 20 74 <b>HUNGARY</b> ESAB Kft Budapest Tel: +36 1 20 44 182 Fax: +36 1 20 44 186 <b>ITALY</b> ESAB Saldatura S.p.A. Bareggio (Mi) Tel: +39 02 97 96 8.1 Fax: +39 02 97 96 87 01 <b>THE NETHERLANDS</b> ESAB Nederland B.V. Amersfoort Tel: +31 33 422 35 55 Fax: +31 33 422 35 44	<b>NORWAY</b> AS ESAB Larvik Tel: +47 33 12 10 00 Fax: +47 33 11 52 03 <b>POLAND</b> ESAB Sp.zo.o. Katowice Tel: +48 32 351 11 00 Fax: +48 32 351 11 20 <b>PORTUGAL</b> ESAB Lda Lisbon Tel: +351 8 310 960 Fax: +351 1 859 1277 <b>ROMANIA</b> ESAB Romania Trading SRL Bucharest Tel: +40 316 900 600 Fax: +40 316 900 601 <b>RUSSIA</b> LLC ESAB Moscow Tel: +7 (495) 663 20 08 Fax: +7 (495) 663 20 09 <b>SLOVAKIA</b> ESAB Slovakia s.r.o. Bratislava Tel: +421 7 44 88 24 26 Fax: +421 7 44 88 87 41 <b>SPAIN</b> ESAB Ibérica S.A. Alcalá de Henares (MADRID) Tel: +34 91 878 3600 Fax: +34 91 802 3461 <b>SWEDEN</b> ESAB Sverige AB Gothenburg Tel: +46 31 50 95 00 Fax: +46 31 50 92 22 ESAB international AB Gothenburg Tel: +46 31 50 90 00 Fax: +46 31 50 93 60 <b>SWITZERLAND</b> ESAB AG Dietikon Tel: +41 1 741 25 25 Fax: +41 1 740 30 55 <b>UKRAINE</b> ESAB Ukraine LLC Kiev Tel: +38 (044) 501 23 24 Fax: +38 (044) 575 21 88	<b>North and South America</b> <b>ARGENTINA</b> CONARCO Buenos Aires Tel: +54 11 4 753 4039 Fax: +54 11 4 753 6313 <b>BRAZIL</b> ESAB S.A. Contagem-MG Tel: +55 31 2191 4333 Fax: +55 31 2191 4440 <b>CANADA</b> ESAB Group Canada Inc. Mississauga, Ontario Tel: +1 905 670 02 20 Fax: +1 905 670 48 79 <b>MEXICO</b> ESAB Mexico S.A. Monterrey Tel: +52 8 350 5959 Fax: +52 8 350 7554 <b>USA</b> ESAB Welding & Cutting Products Florence, SC Tel: +1 843 669 44 11 Fax: +1 843 664 57 48 <b>Asia/Pacific</b> <b>AUSTRALIA</b> ESAB South Pacific Archerfield BC QLD 4108 Tel: +61 1300 372 228 Fax: +61 7 3711 2328 <b>CHINA</b> Shanghai ESAB A/P Shanghai Tel: +86 21 2326 3000 Fax: +86 21 6566 6622 <b>INDIA</b> ESAB India Ltd Calcutta Tel: +91 33 478 45 17 Fax: +91 33 468 18 80 <b>INDONESIA</b> P.T. ESABindo Pratama Jakarta Tel: +62 21 460 0188 Fax: +62 21 461 2929 <b>JAPAN</b> ESAB Japan Tokyo Tel: +81 45 670 7073 Fax: +81 45 670 7001 <b>MALAYSIA</b> ESAB (Malaysia) Snd Bhd USJ Tel: +603 8023 7835 Fax: +603 8023 0225 <b>SINGAPORE</b> ESAB Asia/Pacific Pte Ltd Singapore Tel: +65 6861 43 22 Fax: +65 6861 31 95	<b>SOUTH KOREA</b> ESAB SeAH Corporation Kyungnam Tel: +82 55 269 8170 Fax: +82 55 289 8864 <b>UNITED ARAB EMIRATES</b> ESAB Middle East FZE Dubai Tel: +971 4 887 21 11 Fax: +971 4 887 22 63 <b>Africa</b> <b>EGYPT</b> ESAB Egypt Dokki-Cairo Tel: +20 2 390 96 69 Fax: +20 2 393 32 13 <b>SOUTH AFRICA</b> ESAB Africa Welding & Cutting Ltd Durbanvill 7570 - Cape Town Tel: +27 (0)21 975 8924  <b>Distributors</b> <i>For addresses and phone numbers to our distributors in other countries, please visit our home page</i> <a href="http://www.esab.com">www.esab.com</a>
---	--	--	---



[www.esab.com](http://www.esab.com)

